

Spareparts catalogue

Onderdelencatalogus

Precision chop Loaderwagen

Opraapsnijwagen

Rapide 130E / 160 / 200

Type: Casimiro 1999



Schuitemaker

Contents

Guidelines for ordering spare parts	3
1. Single-sided Wide-angle coupling with cam-type coupling	5
2. Floor chain with drive Rapide 130E	7
3. Floor chain with double drive Rapide 160 and 200	9
4. Towbar	11
5. Rotor Gearbox	13
6. Floor driving gear	15
7. Rotor intake with gear	17
8. Pick-up Suspensio with drive (5-Rows) Rapide 130E and 160	19
9. Pick-up Suspension with drive (6-Rows) Rapide 200	21
10. Single runner wheel Rapide 200	23
11. 5-Rows Pick-up Rapide 130E and 160	25
12. 6-Rows Pick-up Rapide 200	27
13. Chopping device	29
14. Feed roller	31
15. Hydraulic parking support	33
16. Tandemframe TAP-BPW Rapide 130E	35
17. Tandemframe Spring assemblie	37
18. Gigant Spring assemblies	39
19. Track following wheel axle	41
20. Wheel axles ADR	43
21. Wheel axles Colaert ((Typ 1110) Brake 406×120) Rapide 160 en 200	45
22. Hydraulic/Elektrical operation	47
23. Front board Rapide 130E	49
24. Front board Rapide 160 and 200	51
25. Tailgate	53
26. Steel construction + cords as windcover	55
27. Hydraulic system Rapide 130E	57
28. Hydraulic system Rapide 160 and 200	59
29. Electrical circuit diagram Rapide S	61

GUIDELINES FOR ORDERING SPARE PARTS

If you follow the rules stated below when ordering spare parts, you will be assured of a fast and correct delivery.

1. State the model, year of construction and serial number of your Rapide.
2. State both the full number of the part (if known) and the description.
3. State how the part needs to be despatched.
4. When ordering wheel axle parts, it is also advisable to state the wheel axle type. This can be found on the type plate of the wheel axle.

The numbers of the parts of the SCHUITEMAKER-wagons can be found in the first column below the heading *SR-no.* These can be ordered from:

SCHUITEMAKER Machines B.V. Rijssen - The Netherlands
Postbus 219 - 7460 AE Rijssen - The Netherlands
Tel: 0031 548 514125
Fax: 0031 548 516840
Spare Parts Dept.
Ext. 41

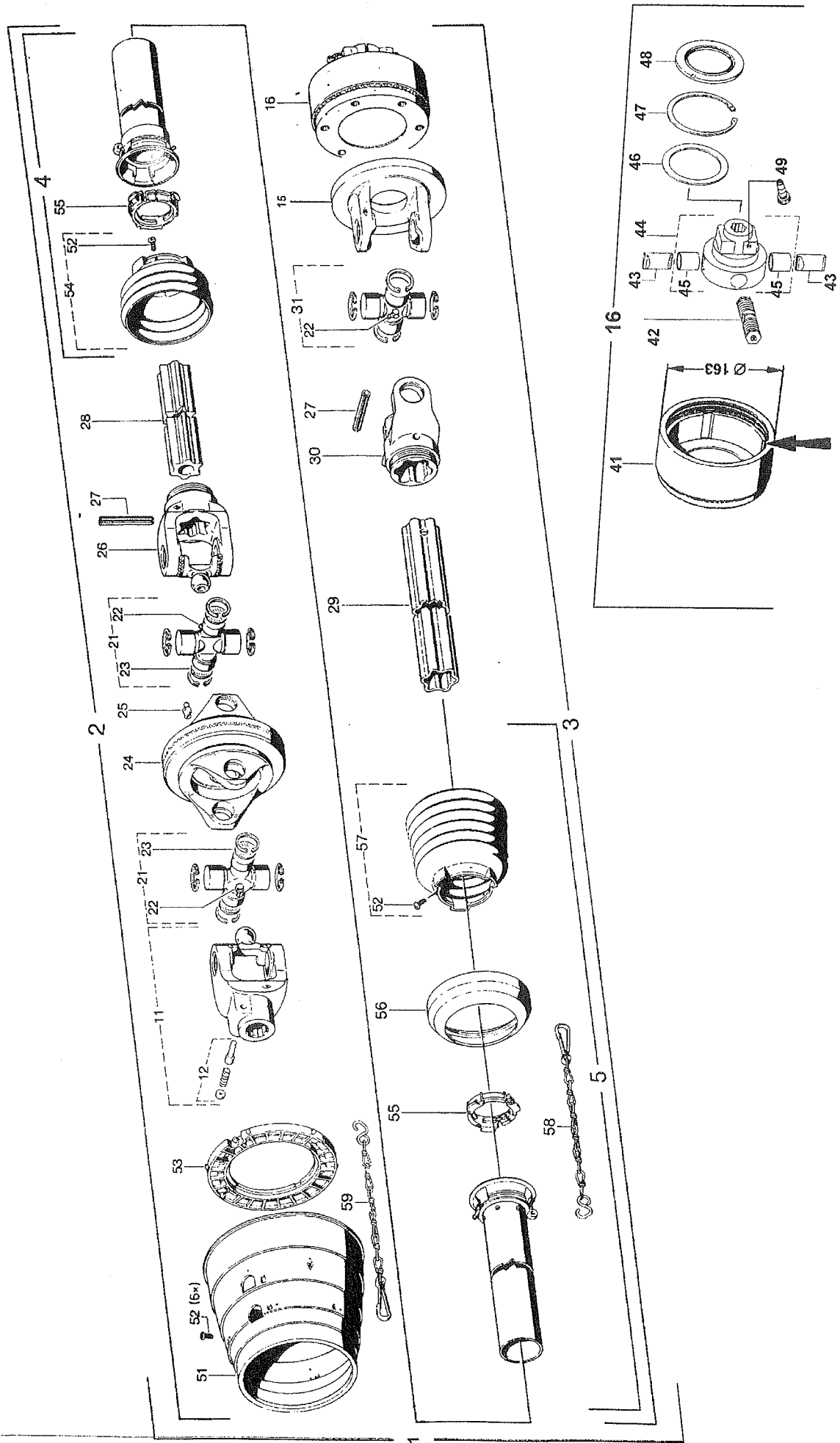

1. SINGLE-SIDED WIDE-ANGLE COUPLING WITH CAM-TYPE COUPLING

ENKELZIJDIGE GROOTHOEK-KOPPELINGSAS MET NOKKENKOPPELING

<i>Fig.</i>	<i>SR-no.</i>	<i>Omschrijving</i>	<i>Description</i>
1	354.145	Koppelingsas WWE 2480 1350 Nm cpl.	Coupling shaft WWE 2480 1350 Nm cpl.
4	455.020	Buitenbeschermbuis met kap	Outside protection tube with cover
	455.153	Buitenbeschermbuis compl. met kap	Outside protection tube complete with cover
	455.021	Binnenbeschermbuis	Inner protection tube
	455.152	Binnenbeschermbuis compl. met kap	Inner protection tube complete with cover
11	455.048	Groothoek-opsteekgaffel	Wide-angle set-up fork
12	455.046	Drukstift Set (Agra 101)	Locking pin set (Agra 101)
15	455.054	Flensgaffel	Flange fork
16	455.111	Nokkenschakelkoppeling 1350 Nm	Cam-type coupling 1350 Nm
21	455.056	Groothoek-kruisstuk (incl. 7 en 8)	Wide-angle cross-piece (incl. 7, 8)
22	342.105	Smeernippel M8×1	Grease nipple M8×1
24	455.049	Dubbel-gaffel	Double fork
25	342.105	Smeernippel M8×1	Grease nipple M8×1
26	455.091	Profielgaffel	Profiled fork
27	312.130	Spanstift DIN 1481-10×80	Clamping pin DIN 1481-10×80
28	455.093	Sterbuis (binnen) S4GA	Profiled tube (inside) S4GA
29	455.094	Sterbuis (buiten) S5	Profiled tube (outside) S5
30	455.092	Profielgaffel	Profiled fork
31	455.055	Kruisstuk	Cross-piece complete
53	455.155	Glijring	Sliding ring
54	455.154	Beschermkap met schroef (incl. 15)	Protective cover with screw (incl. 15)
55	455.155	Glijring	Sliding ring
56	455.088	Steunring	Supporting ring
57	455.154	Beschermtrechter	Safety cover
59	450.035	Borgketting	Locking chain

1.1. CAM-TYPE COUPLING

NOKKENSCHAKELKOPPELING

<i>Fig.</i>	<i>SR-no.</i>	<i>Omschrijving</i>	<i>Description</i>
16	455.111	Nokkenschakelkoppeling 1350 Nm	Cam-type coupling 1350 Nm
41	455.067	Koppelingshuis (rechtsdraaiend)	Coupling housing (clockwise)
42	455.077	Schakelnok 1350 Nm	Switch cam 1350 Nm
43	455.065	Blokkeernok	Locking cam
44	455.063	Naaf	Hub
45	455.064	Glijbus	Sliding sleeve
46	455.061	Dichtring	Sealing ring
47	313.214	Binnenborgring	Locking ring, inside
48	455.062	Steunring	Supporting ring
49	455.096	Klemkonus	Clamping cone

2. FLOOR CHAIN WITH DRIVE RAPIDE 130E

BODEMKETTING MET AANDRIJVING RAPIDE 100E

<i>Fig.</i>	<i>SR-no.</i>	<i>Omschrijving</i>	<i>Description</i>
2	401.107	Kogellager 6306-2RS	Ball bearing 6306-2RS
3	361.119	Nilosring 6306-AV	Nilos ring 6306-AV
4	941.042	Glandlagerhuis	Gland bearing housing
5	316.904	Veerring 12 mm	Spring ring 12 mm
6	302.615	Cilinderkopbout M12×35	Cylinder head bolt M12×35
7	402.154	Steunlagerblok 45	Suspension bearing block 45
8	966.001	Steunlagerhuis	Suspension bearing housing
9	303.958	Spanbout M16	Tensioning bolt M16
10	315.121	Spie 14×9×80	Feather key 14×9×80
11	968.361	Transportkettingas	Transport chain pinion axle
12	355.510	Hydromotor OMP-125	Hydro Motor OMP-125
13	315.103	Spie 8×7×30	Feather key 8×7×30
14	351.024	Zijkast Ø45	Side box Ø45
15	316.917	Bolle veerring C12,5	Spring ring C12,5
16	302.630	Cilinderkopbout M12×25	Cylinder head bolt M12×25
17	967.581	Kettingspanner	Chain tensioner
18	301.745	Bout M16×70	Bolt M16×70
19	925.481	Klembus	Clamping bush
20	942.029	Kettingspan wiel	Chain sprocket
21	313.401	Seegersprengring SB72	Seeger circlip-SB72
22	316.901	Veerring 16 mm	Spring ring 16 mm
23	306.702	Moer M16	Nut M16
24	967.032	Bodemketting	Floor chain
25	966.069	Kettingstaaf 22/2	Chain rod 22/2
26	431.122	Verbindingschalm	Joining link

3. FLOOR CHAIN WITH DOUBLE DRIVE RAPIDE 160 AND 200

BOBEMKETTING MET DUBBELE AANDRIJVING RAPIDE 160 EN 200

<i>Fig.</i>	<i>SR-no.</i>	<i>Description</i>	<i>English</i>
2	401.107	Kogellager 6306 - 2RS	Ball bearing 6306 - 2RS
3	361.119	Nilosring 6306 - AV	Nilos ring 6306-AV
4	377.303	Lagerplaat	Bearing plate
5	316.904	Veerring 12 mm	Spring washer 12 mm
6	302.615	Cilinderkopbout M12×35	Cylinder head bolt M12×35
7	301.735	Bout M12×55	Bolt M12×55
8	316.702	Sluitring A13	Washer A13
9	303.958	Spanbout M16	Tension bolt M16
10	315.121	Spie 14×9×80	Feather key 14×9×80
11a	960.678	Transportkettingas li.	Transport chain pinion axle left
11b	960.679	Transportkettingas re.	Transport chain pinion axle right
12	355.035	Hydromotor OMP-160 Rap.160	Hydro Motor OMP-160 Rap.160
	355.037	Hydromotor OMP-200 Rap.200	Hydro Motor OMP-200 Rap.200
13	315.103	Spie 8×7×30	Key 8×7×30
14	351.024	Zijkast Ø45	Side box Ø45
15	316.917	Bolle veerring C12.5	Spring washer C12,5
16	302.630	Cilinderkopbout M12×25	Cylinder head bolt M12×25
17	967.581	Kettingspanner	Chain tensioner
18	301.745	Bout M16×70	Bolt M16×70
19	925.481	Klembus	Clamping bush
20	942.029	Kettingspanwiel	Chain sprocket
21	313.401	Seegersprengring SB72	Seeger circlip SB72
22	316.901	Veerring 16 mm	Spring washer 16 mm
23	306.702	Moer M16	Nut M16
24	960.680	Bodemketting (2-delig)	Floor chain (2-part)
	961.149	Bodemketting (2-delig)	Floor chain (2-part)
25	960.694	Kettingstaaf	Chain rod
26	431.153	Verbindingsschalm	Joining link
27	933.978	Bevestigingsschijf	Mounting disc
28	303.932	Verz. bout M12×25	Bolt M12×25
29	306.302	Moer M12	Nut M12

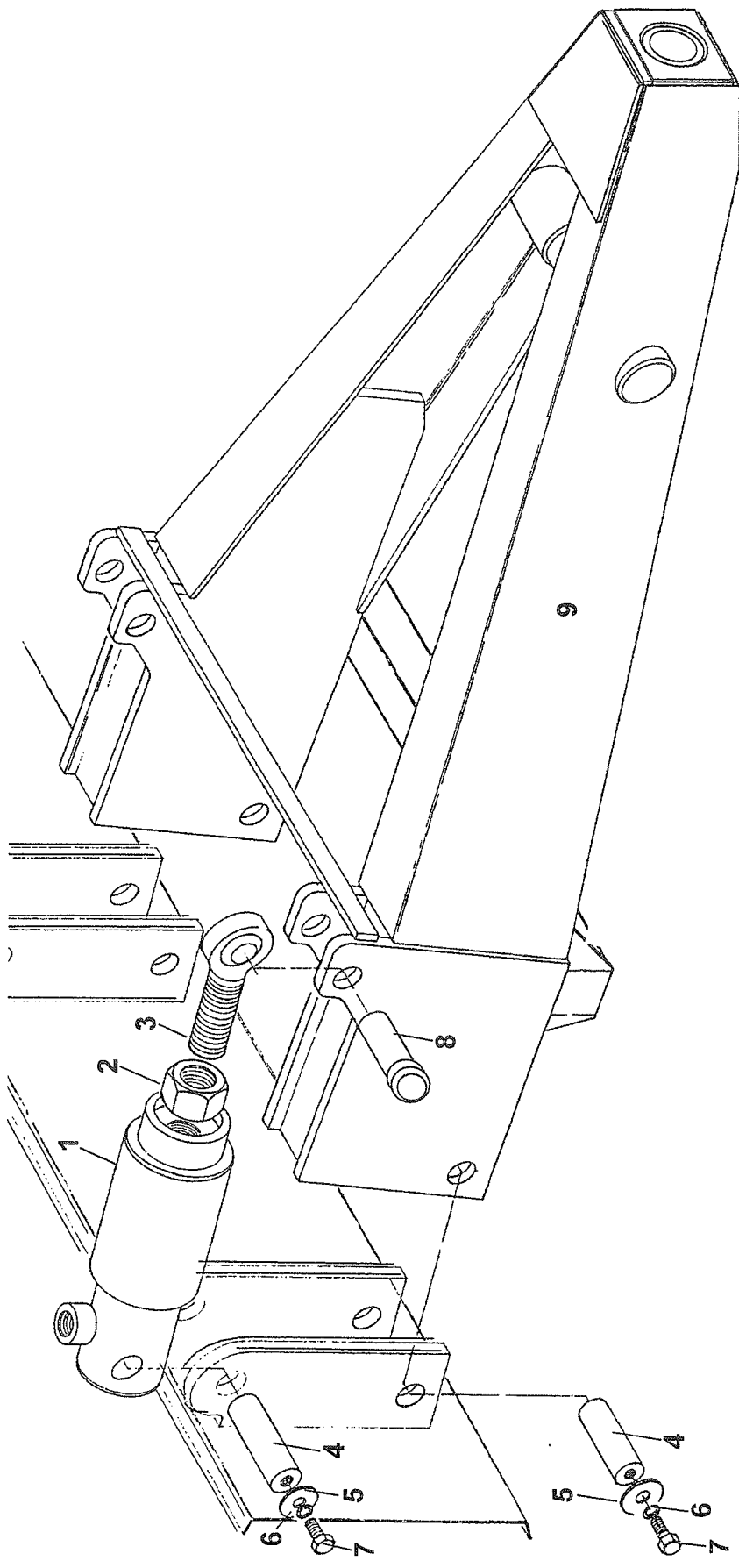

4. TOWBAR

TREKKOP

Drawing no. 975.005

<i>Fig.</i>	<i>SR-no.</i>	<i>Omschrijving</i>	<i>Description</i>
1	355.773	Hydraulische cilinder	Hydr. cylinder
1a	454.808	Set afdichtingen	Set of seals
2	306.716	Moer M39×3	Nut M39×3
3	401.222	Stangkop GAR-40	Rod end GAR-40
4	920.753	Scharnierpen-30	Pivoting pin-30
5	934.149	Sluitring 50/11	Washer 50/11
6	316.906	Veerring 10 mm	Spring washer 10 mm
7	301.805	Tapbout M10×25	Bolt M10×25
8	921.077	Scharnieras-40	Hinge pin-40
9	961.212	Trekkop-E	Tow bar-E

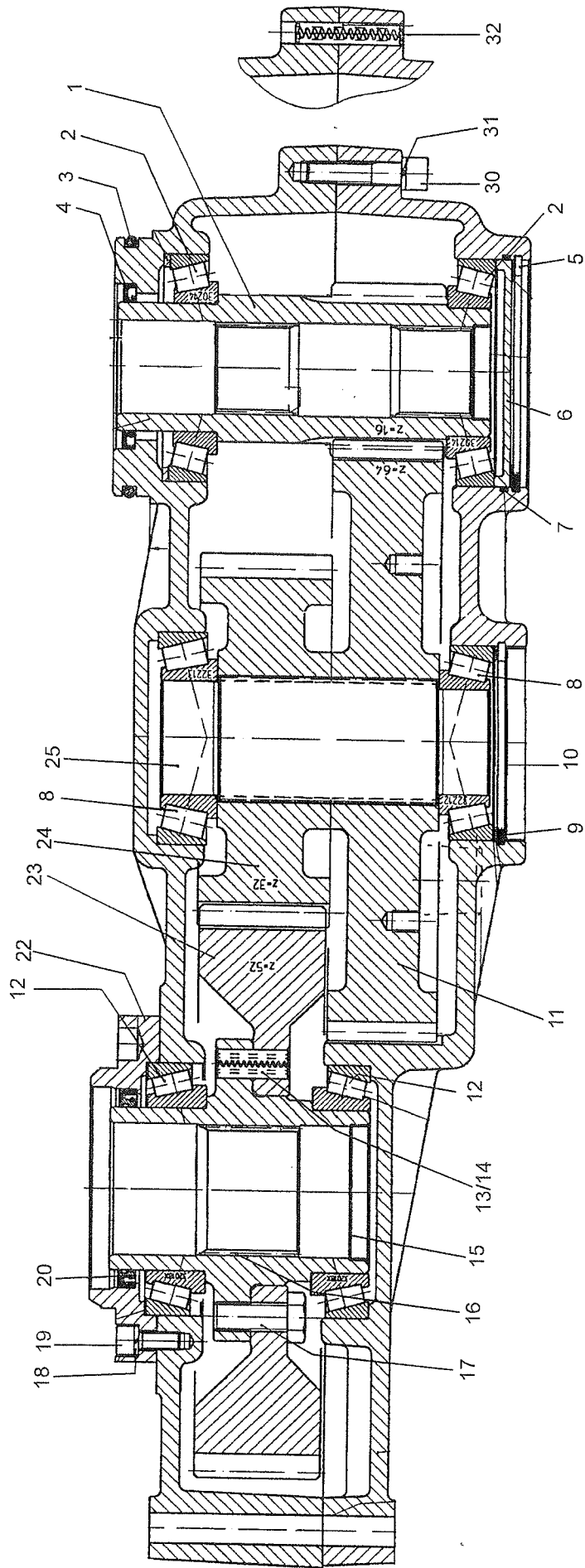

5. ROTOR GEARBOX

ROTOR TANDWIELKAST

Article no. : 351.069

Fig.	SR-no.	Omschrijving	Discription
1	456.066	Rondselas A50x45 Z=16	Pinion Z=14
2	401.197	Kegellager 30214	Cone bearing 30214
3	365.013	O-ring 130x5	O-ring 130x5
4	361.138	Oliekeerring 70x90x7	Oil catcher 70x90x7
5	313.218	Borgring I-125	Locking ring I-125
6	456.071	Deksel-125	Cover-125
7	365.015	O-ring 125x3	O-ring 125x3
8	401.145	Kegellager 32212	Cone bearing 32212
9	313.216	Borgring I-110	Locking ring I-110
10	349.098	Deksel 110	Cover 110
11	456.067	Tandwiel Z=64	Gear wheel Z=64
12	401.149	Kegellager 32018	Cone bearing 32018
13	312.136	Spanhuls 16x40	Clamping sleeve 16x40
14	312.135	Spanhuls 10x40	Clamping sleeve 10x40
15	349.092	Deksel 75	Cover 75
16	456.069	Profielnaaf A72	Nave with splines A72
17	302.644	Bout M16x1,5x40	Bolt M16x1,5x40
18	316.906	Veerring 10mm	Spring washer 10mm
19	302.601	Cilinderkopbout M10x25	Cylinder head bolt M10x25
20	361.149	Oliekeerring 90x110x10	Oil catcher 90x110x10
22	456.071	Lagerdeksel	Bearing cover
23	456.068	Tandwiel Z=52	Gear wheel Z=52
24	456.072	Tandwiel Z=32	Gear wheel Z=32
25	456.073	Profielas	Shaft with splines
30	302.642	Cilinderkopbout M12x45	Cylinder head bolt M12x45
	302.643	Cilinderkopbout M12x55	Cylinder head bolt M12x55
	302.616	Cilinderkopbout M12x100	Cylinder head bolt M12x100
31	316.904	Veerring 12mm	Spring washer 12mm
32	312.137	Spanhuls 12x60	Clamping sleeve 12x60
	456.019	Ontluchtingsnippel M 18x1,5	Air release plug M18x1,5
	355.279	Vulplug M18x1,5	Drain plug M18x1,5
	456.058	Aftapplug magn. M18x1,5	Drain plug magn. M18x1,5
	364.025	Dichtring 18x24x1,5	Sealing ring 18x24x1,5

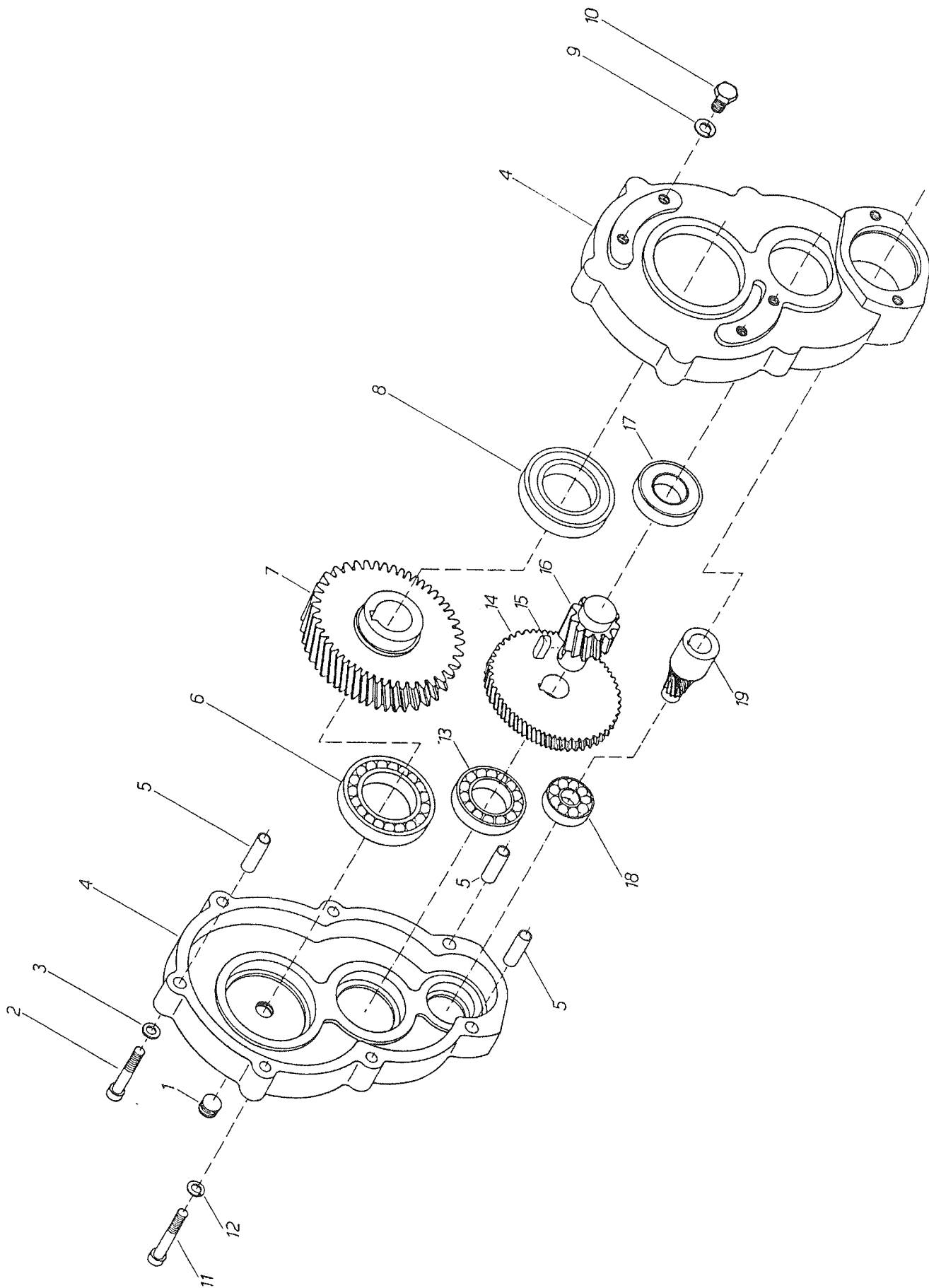

6. FLOOR DRIVING GEAR

BODEM-AANDRIJFKAST

Article no. : 351.024

<i>Fig.</i>	<i>SR-no.</i>	<i>Omschrijving</i>	<i>Description</i>
1	381.111	Draadstop M20×1,5	Screw plug M20×1.5
2	302.013	Cilinderbout M10×65	Cylinder head bolt M10×65
3	316.906	Veerring 10 mm	Spring washer 10 mm
4	450.766	Tandwielkast (2-delig)	Gearcase (2-parts)
5	312.127	Spanhuls 13×50	Clamping sleeve 13×50
6	401.176	Kogellager 6013	Ball bearing 6013
7	456.043	Tandwiel met gat Ø45	Gear wheel with hole Ø45
8	401.177	Kogellager 6013-2RS	Ball bearing 6013-2RS
9	316.917	Bolle veerring 12,5 mm	Spring washer 12.5 mm
10	301.807	Tapbout M12×25	Bolt M12×25
11	302.613	Cilinderkopbout M10×70	Cylinder head bolt M10×70
12	316.705	Sluitring A 10,5	Washer A 10,5
13	401.118	Kogellager 6009	Ball bearing 6009
14	450.769	Tandwiel	Gear wheel
15	315.103	Inlegspie 8×7×30	Key 8×7×30
16	450.768	Tandrondsel	Pinion
17	401.175	Kogellager 6207-2RS	Ball bearing 6207-2RS
18	451.031	Kogellager 6304	Ball bearing 6304
19	450.767	Tandas	Pinion

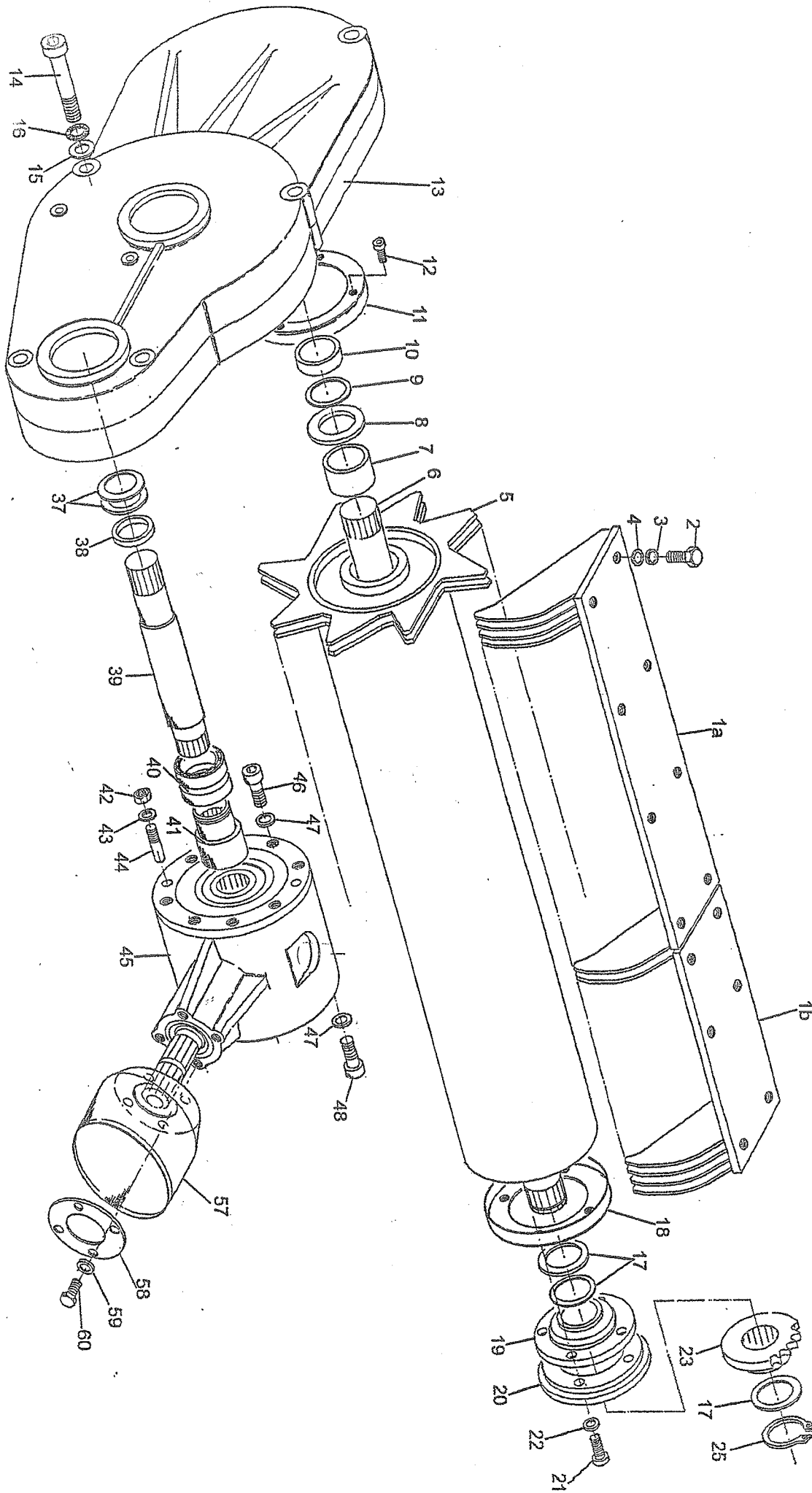

7. ROTOR INTAKE WITH GEAR

ROTORINVOER MET AANDRIJVING

Drawing no. 975.025

Fig.	SR-no.	Omschrijving	Description
1a	961.544	Afstrijkerlijst lang	Stripper frame long
1b	961.545	Afstrijkerlijst kort	Stripper frame short
	934.383	Afstrijker	Stripper
2	301.803	Tapbout M12x20	Tap bolt M12x20
3	316.902	Tandveerring J12	Toothed spring ring J12
4	316.702	Sluitring A13	Washer A13
5	961.380	Rotor 4T-A72x66	Rotor 4T-A72x66
6	921.273	Rotoras B72x66	Rotor shaft B72x66
7	402.211	Glijlager N72100	Slide bearing N72100
8	403.135	Loopschijf LS-75100	Counting disc LS-75100
9	349.088	Vulschijf PS-75x 95x0,5	Filler disc PS-75x95x0,5
	349.089	Vulschijf PS-75x 95x1	Filler disc PS-75x95x1
	349.090	Vulschijf PS-75x 95x2	Filler disc PS-75x 95x2
10	926.336	Afstandbus 7228	Spacing sleeve 7228
11	967.778	Afdichtring 60/M8	Sealing ring 60/M8
12	302.607	Cilinderkopbout M8x20	Cylinder head bolt M8x20
13	351.069	Rotortandwielkast A72x66 (zie blz.xx)	Rotor gearbox A72x66 (Page xx)
14	302.637	Cilinderkopbout M16x160	Cylinder head bolt M16x160
	302.639	Cilinderkopbout M16 x 200	Cylinder head bolt M16 x 200
15	316.707	Sluitring A17	Plain washer A17
16	316.919	Tandveerring J16,5	Toothed spring ring J16,5
17	349.044	Vulschijf 60x75x1	Filler disc 60x75x1
	349.045	Vulschijf 60x75x0,5	Filler disc 60x75x0,5
	349.047	Vulschijf 60x75x2	Filler disc 60x75x2
18	967.225	Afdichtring 60/M16	Sealing ring 60/M16
19	900.132	Kogellager RME 60/192	Ball bearing RME 60/192
20	936.809	Eindflens 60	End flange 60
21	301.735	Pl. verz. bout M16x60	Countersunk bolt M 16x60, flat
23	953.673	Kettingwiel 3/4"-26 met breekbout Rap.130E en 160	Chainsprocket 3/4"-26 with shearing bolt ; Rap. 130E and 160
	900.311	Breekbout M12x62	Chearing bolt M12x62
23a	953.672	Kettingwiel 1"-21 met breekbout Rap.200	Chainsprocket 1"-21 with shearing bolt Rap. 200
	900.311	Breekbout M12x55	Shearing bolt M12x55
25	313.212	Borgring A-60	Locking ring A-60
37	456.064	Schotelring	Belleville washer
38	456.063	Stuurring	Ring
39	456.060	Drijfjas B50x45	Rotor drive shaft B50x45
40	401.208	Kogellager 6209-2RS	Ball bearing 6209-2RS
42	306.704	Moer M12	Nut M12
43	316.702	Sluitring A13	Washer A13
44	456.018	Paspen 12M6x47	Dowel 12M6x47
45	351.066	Tandwielkast WG13>28	Gear box WG13>28
46	302.623	Cilinderkopbout M16x40	Cylinder head bolt M16x40
47	316.919	Veerring 16mm	Spring washer 16mm
48	302.640	Cilinderkopbout M16x50	Cylinder head bolt M16x50
57	900.116	Beschermtrichter	Protecticve cover
58	934.136	versterkingsring	Reinforcing ring
59	316.906	Veerring 10mm	Spring ring 10mm
60	301.805	Bout M10x25	Bolt M10x25

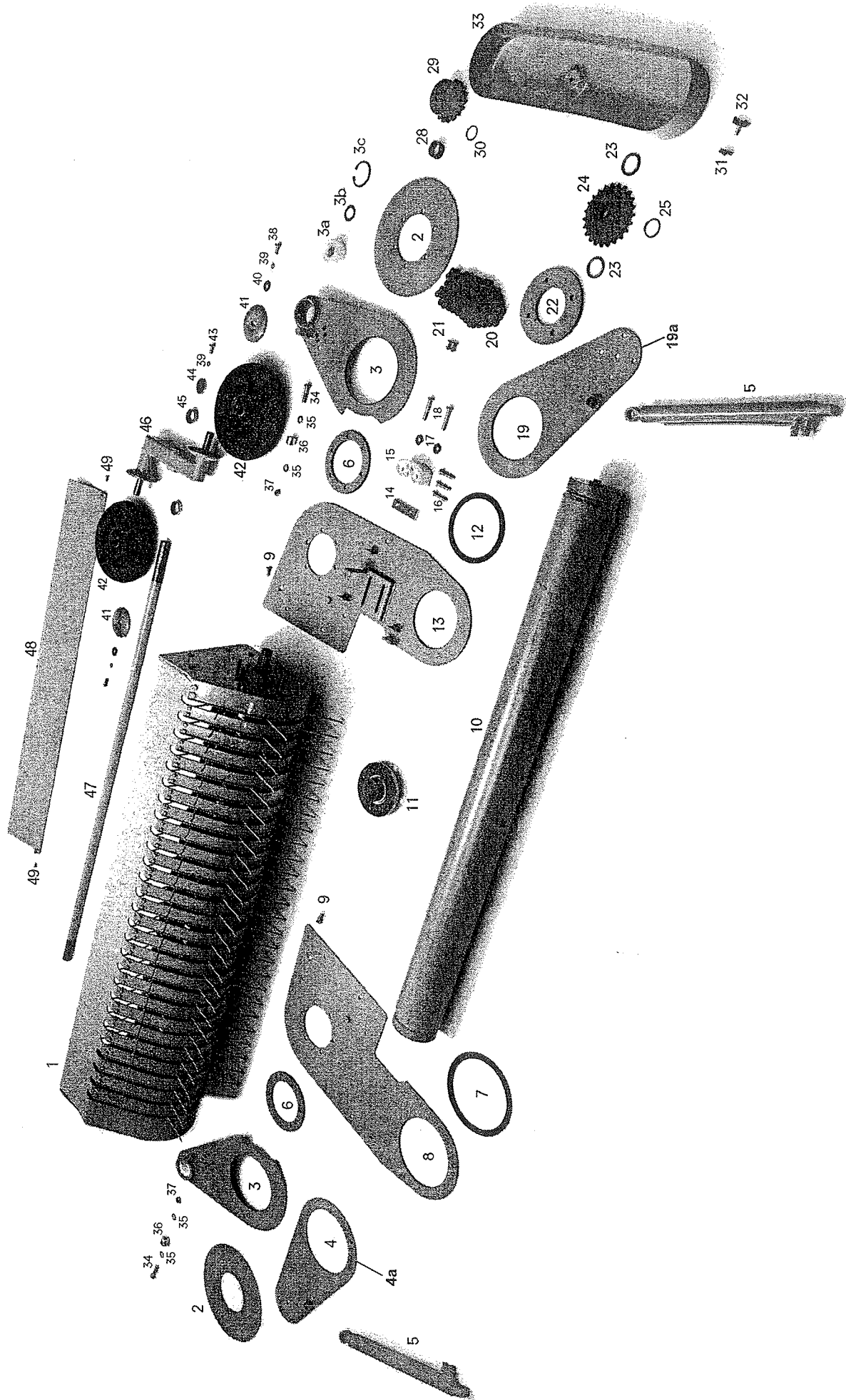

8. PICK-UP SUSPENSIO WITH DRIVE (5-ROWS) RAPIDE 130E AND 160

PICK-UP OPHANGING MET AANDRIJVING (5-BALKS) RAPIDE 13E EN 160

Fig.	SR-no.	Omschrijving	Description
1	433.108	5-balks Pick-up compleet	Pick-up, 5 rows, complete
2	935.425	Buitenschijf	Outer disc
3	968.731	Loopwiel plaat	Runner wheel plate
3a	402.203	Glijlager N3536	Slide bearing N3536
3b	403.129	Axiaalschijf AS 3552	Axial disc AS 3552
3c	313.215	Binnenborgring	Locking ring, inside
4	961.527	Rolplaat rechts Rap.130E	Roller plate right Rap.13E
	961.529	Pick-up hefplaat rechts Rap.160	Pick-up lifting plate right Rap.160
5	355.770	Hydraulische cilinder (incl. 5a en b)	Hydr. cylinder (incl. a and b)
5a	402.128	Glijlager 20/20	Slide bearing 20/20
5b	454.810	Set afdichtingen t.b.v N° 5	Set of seals for N° 5
6	934.073	Binnenschijf	Inner disc
7	402.208	U-glijlager 192	U-slide bearing 192
8	953.731	Pick-up plaat 60-re.	Pick-up plate 60-right
9	303.948	Pl. verzonken bout M10×30	Countersunk bolt M10×30
10	953.503	Invoerrol Rap.130E (zie blz. xx)	Feed roller Rap.130E (See page xx)
	953.574	Invoerrol Rap.160 (zie blz. xx)	Feed roller Rap.160 (See page xx)
11	900.132	Flenslager RME 60/192	Flange bearing RME 60/192
12	402.208	U-glijlager 192	U-slide bearing 192
13	953.742	Pick-up plaat 60-li.	Pick-up plate 60-left
14	912.671	Spanstrip TB-10	Tensioning strip TB-10
14a	302.935	Spanbout M10×140	Tension bolt M10×140
15	353.202	Spanblok	Tension block
17	316.719	Sluitplaat 10,5 mm	Washer 10.5 mm
18	301.726	Bout M10×60	Bolt M10×60
19	961.526	Rolplaat links Rap.130E	Roller plate left Rap.130E
	961.528	Pick-up hefplaat links Rap.160	Pick-up lifting plate left Rap.160
20	356.128	Ketting ¾" × ½"-77	Chain ¾" × ½"-77
21	356.129	Verbindingsschakel ¾" × ½"	Joining link ¾" × ½"
22	936.809	Eindflens 60/8	End flange 60/8
24	953.673	Kettingwiel ¾"-26 met breekbout	Chain wheel ¾"-26 with shearing bolt
24a	900.211	Breekbout M12x62	Shearing bolt M12x62
25	313.121	Buitenborgring A60	Locking ring A60, outside
28	926.164	Ring - 27	Ring - 27
29	353.350	Kettingwiel ¾"-19/35	Chain wheel ¾"-19/35
30	313.105	Buitenborgring A35	Locking ring A35
31	306.359	Plaatmoer M8 zelfborgend	Self-locking plate nut M8
32	301.801	Bout M8×16	Bolt M8×16
32a	316.722	Sluitplaat 8,4 mm	Washer 8,4 mm
33	375.501	Beschermkap	Protective cover
34	301.715	Bout M12×45	Bolt M12×45
35	316.702	Sluitring A13	Washer A13
36	921.024	Aanslagnok	Stop boss
37	306.302	Zelfborgende moer M12	Self-locking nut M12
38	301.809	Tapbout M10×20	Bolt M10×20
39	316.906	Veerring 10 mm	Spring washer 10 mm
40	316.715	Sluitring R 11	Washer R 11
41	934.474	Afdekkapje buiten	Guard, outer
42	432.790	Wiel 4.00×4-6 Pr.	Wheel 4.00×4-6 Pr.
43	301.811	Tapbout M10×30	Bolt M10×30
44	934.149	Sluitring 50/11	Washer 50/11
45	402.141	Glijlager 35/20	Slide bearing 35/20
46	967.432	Loopwielenarm	Runner wheel arm
47	920.839	Loopwielenas	Runner wheel shaft
48	968.343	Achterplaat	Back plate
49	303.912	Pl. verzonken bout M8×20	Countersunk bolt M8×20

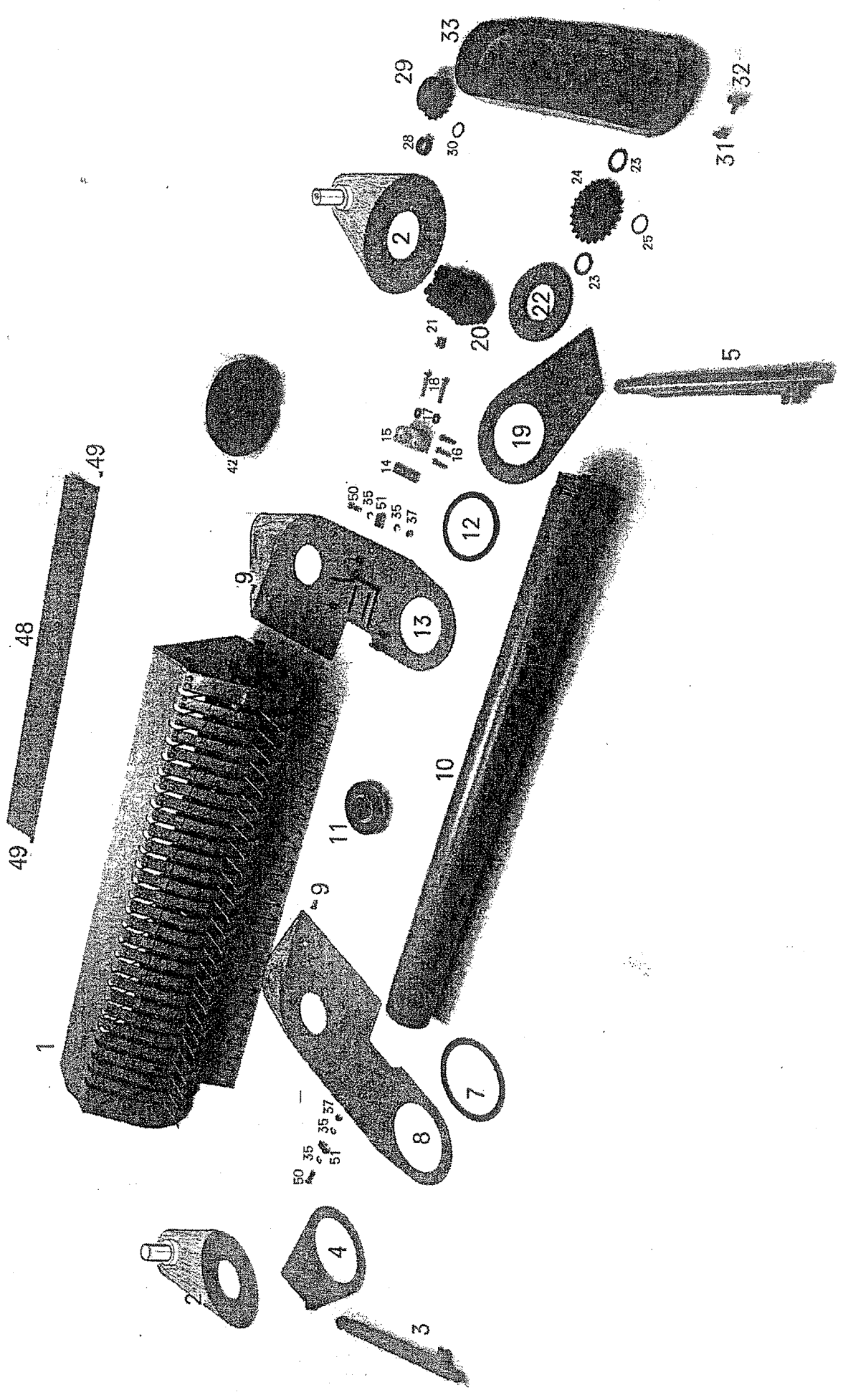

9. PICK-UP SUSPENSION WITH DRIVE (6-ROWS) RAPIDE 200

PICK-UP OPHANGING MET AANDRIJVING (6 BALKS) RAPIDE 200

<i>Fig.</i>	<i>SR-no.</i>	<i>Omschrijving</i>	<i>Description</i>
1	433.114	6-balks Pick-up compl.	Pick-up, 6 rows, complete
2	961.532	Buitenplaat met verstelpen li.	Outer plate with adjusting bolt left
	961.533	Buitenplaat met verstelpen re.	Outer plate with adjusting bolt, right
4	961.529	Pick-up hefplaat rechts	Pick-up lifting plate right
5	355.770	Hydraulische cilinder (incl. 5a en b)	Hydr. cylinder (incl. 5a and b)
5a	402.128	Glijlager 20/20	Slide bearing 20/20
5b	454.810	Set afdichtingen t.b.v. N° 5	Set of seals for N° 5
7	402.208	U-glijlager 192	U-Slide bearing 192
8	953.745	Pick-up plaat R8/P6 rechts	Pick-up plate R8/P6 right
9	303.948	Pl. verzonken bout M10×30	Countersunk bolt M10×30
10	953.574	Invoerrol Ø140 (zie blz. 39)	Feed roller Ø140 (See page 39)
11	900.132	Flenslager RME 60/192	Flange bearing RME 60/192
12	402.208	U-Glijlager 192	U-Slide bearing 192
13	953.744	Pick-up plaat R8/P6 links	Pick-up- plate R8/P6 left
14	912.671	Spanstrip TB-10	Tensioning strip TB-10
14a	302.935	Spanbout M10×140	Tension bolt M10×140
15	353.202	Spanblok	Tension block
17	316.719	Sluitplaat 10,5 mm	Washer 10.5 mm
18	301.726	Bout M10×60	Bolt M10×60
19	961.528	Pick-up hefplaat links	Pick-up lifting plate, left
20	356.192	Ketting 1"-63	Chain 1"-63
21	356.144	Verloopschalm 1"	Adapter link 1"
	356.143	Verbindingsschakel 1"	Joining link 1"
22	936.809	Eindflens 60	End flange 60
24	953.672	Kettingwiel 1"-21 met breekbout	Chain wheel 1"-21 with shearing bolt
24a	900.311	Breekbout M12x55	Shearing bolt M12x55
25	313.121	Buitenborgring A60	Locking ring A60, outside
29	953.689	Kettingwiel 1"-18 met vrijloop	Chain wheel 1"-18, with freewheel device
30	921.279	Eindschijf	End disc
30a	403.121	Schijf AS-3047	Disc AS-3047
30b	303.932	Verz.bout M12x25	Countersunk bolt M12x25
31	306.359	Plaatmoer M8 zelfborgend	Self-locking nut M8
32	301.801	Bout M8×16	Bolt M8×16
32a	316.722	Sluitplaat 8,4 mm	Washer 8.4 mm
33	375.512	Beschermkap	Protective cover
34	301.715	Bout M12×45	Bolt M12×45
35	316.702	Sluitring A13	Washer A13
37	306.302	Zelfborgende moer M12	Self-locking nut M12
38	301.809	Tapbout M10×20	Bolt M10×20
39	316.906	Veerring 10 mm	Spring washer 10 mm
40	316.715	Sluitring R 11	Washer R 11
42	432.906	Wiel 18/8.5-8 4 Pr.	Wheel 18/8.5-8 4 Pr.
48	968.343	Achterplaat	Rear plate
49	303.912	Pl. verzonken bout M8×20	Countersunk bolt M8×20
50	301.804	Tapbout M12×35	Bolt M12×35
51	913.271	Hefblok	Lifting block
51a	281.028	Slijtstrip	Wear strip
51b	913.272	Steunstrip	Support strip

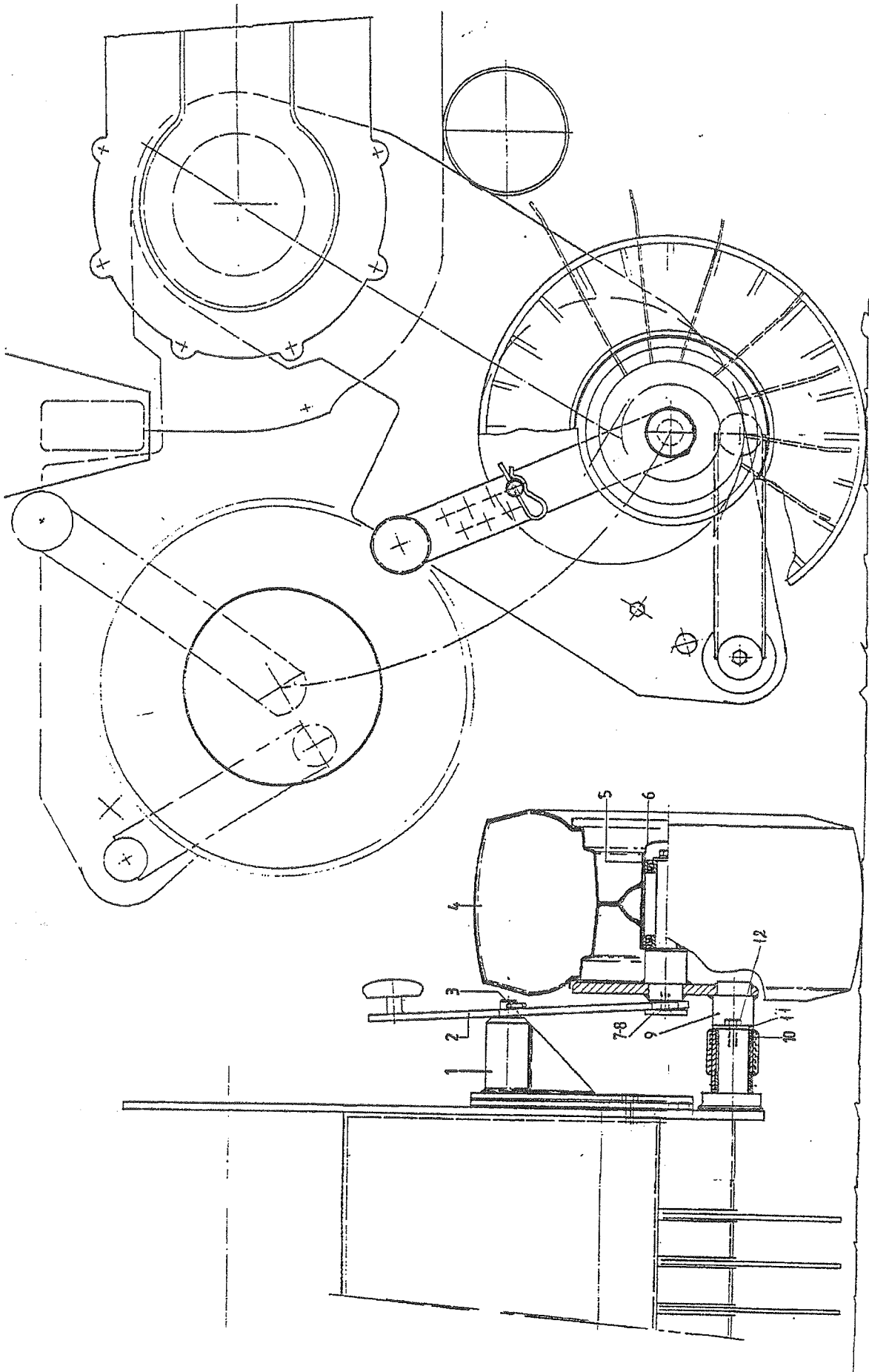

10. SINGLE RUNNER WHEEL RAPIDE 200

SINGLE RUNNER WHEEL SET RAPIDE 200

<i>Fig.</i>	<i>SR-no.</i>	<i>Omschrijving</i>	<i>Description</i>
1	961.532	Buitenplaat met verstelpen li.	Outer plate with adjusting bolt left
	961.533	Buitenplaat met verstelpen re.	Outer plate with adjusting bolt right
2	912.945	Verstelstrip	Adjusting strip
2a	323.104	Knop	Knob
3	375.101	Steekborgveer 4 mm	Spring clip 4 mm
4	432.907	Wiel 18/8.5-8 4Pr.	Wheel 18/8.5-8 4Pr.
5	401.143	Kogellager 6205-2RS	Ball bearing 6205-2RS
6	349.060	Naafdop 52/26	Hub cap 52/26
7	935.994	Sluitring	Washer
8	303.924	Plat-verzonkenbout M10×20	Countersunk bolt M10×20, flat
9	960.381	Loopwielarm Links	Runner arm left
	960.382	Loopwielarm Rechts	Runner arm right
10	402.141	Glijlager 35/20	Slide bearing 35/20
11	301.814	Bout M10×35	Bolt M10×35
12	316.705	Sluitring A10.5	Washer A10.5
13	306.306	Zelfborgende moer M10	Self-locking nut M10

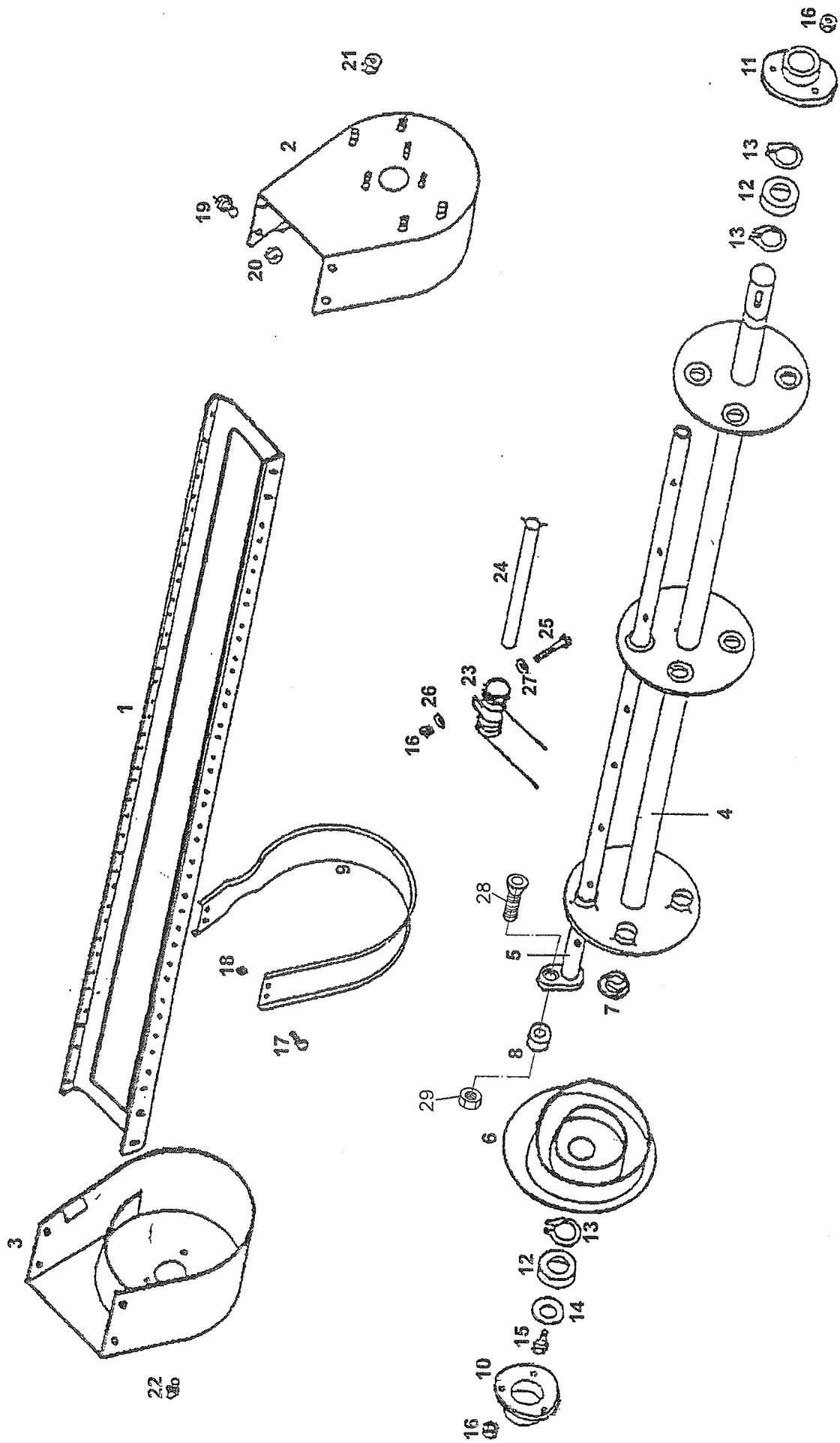

11. 5-ROWS PICK-UP RAPIDE 130E AND 160

5-BALKS PICK-UP RAPIDE 100E EN 160

Article no. complete pick-up: 433.108

<i>Fig.</i>	<i>SR-no.</i>	<i>Omschrijving</i>	<i>Discription</i>
1	-	Frame	Frame
2	458.045	Eindkap left	End cover left
3	458.046	Eindkap rechts	End cover right
4	458.047	Aandrijfvas	Drive shaft
5	458.048	Veeras	Spring shaft
6	458.049	Curve-plaat	Curve plate
7	450.938	Nylonbus	Nylon sleeve
8	401.216	Looprol LR-5201	Roller bearing LR-5201
9	458.050	Geleidebeugel	Guide bracket
10	458.054	Lagerhuis blind	Bearing housing
11	458.055	Lagerhuis met gat	Bearing housing (with hole)
12	401.175	Kogellager 6207-2RS	Ball bearing 6207-2RS
13	313.105	Buitenborgring A35	Locking ring A35, outside
14	934.236	Ring Ø10/40×3	Ring Ø10/40×3
15	301.801	Tapbout M8×16	Bolt M8×16
16	306.312	Zelfborgende moer M8	Self-locking nut M8
17	301.820	Tapbout M6×16	Bolt M6×16
18	306.707	Moer M6	Nut M6
19	301.809	Tapbout M10×20	Bolt M10×20
20	306.701	Moer M10	Nut M10
21	306.704	Moer M12	Nut M12
22	342.103	Smeernippel M10×1-180	Grease nipple M10×1-180
23	458.053	Pick-up tand	Pick-up tine
24	458.051	Tandveerbuis	Tine spring tube
25	301.747	Bout M8×50	Bolt M8×50
26	316.713	Sluitring R9	Washer R9
27	458.052	Klemstukje	Clamping piece
28	303.930	Verz.bout M12x40	Countersunk bolt M12x40
29	458.068	Moer M12	Nut M12

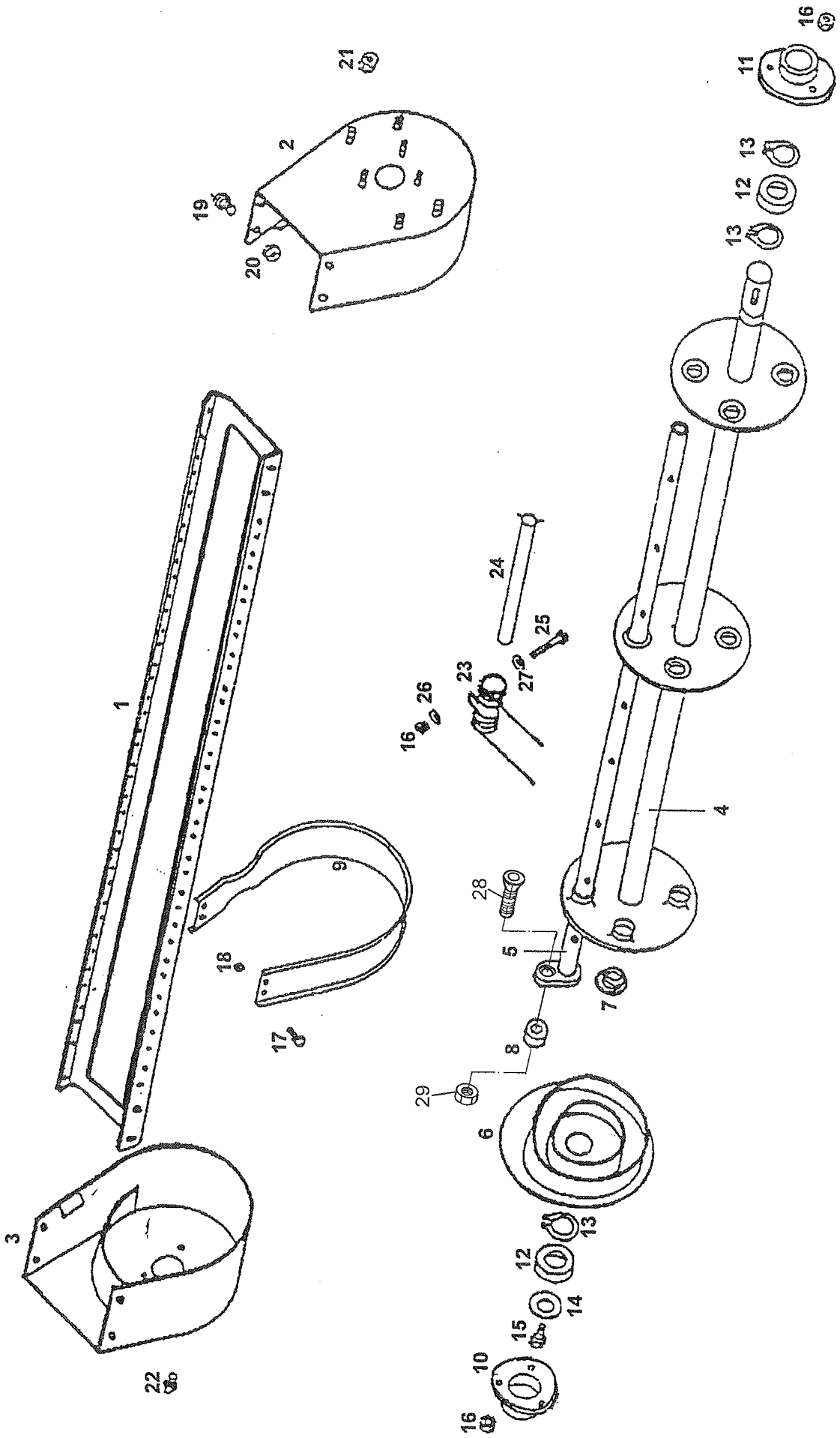

12. 6-ROWS PICK-UP RAPIDE 200

6-BALKS PICK-UP RAPIDE 200

Article no. complete pick-up: 433.114

<i>Fig.</i>	<i>SR-no.</i>	<i>Omschrijving</i>	<i>Discription</i>
1	-	Frame	Frame
2	458.056	Eindkap links	End cover left
3	458.057	Eindkap rechts	End cover right
4	458.070	Aandrijfjas 1.3/4-6	Drive shaft 1.3/4-6
5	458.060	Veeras	Spring shaft
6	458.062	Curve-plaat	Curve plate
7	450.938	Nylonbus	Nylon bush
8	401.216	Looprol LR-6201	Roller bearing LR-6201
9	458.063	Geleidebeugel	Guide bracket
10	458.064	Lagerhuis	Bearing housing
11	458.064	Lagerhuis	Bearing housing
12	401.208	Kogellager 6209-2RS	Ball bearing 6209-2RS
13	313.111	Buitenborgring A45	Locking ring A45
14	934.236	Ring Ø10/40×3	Ring Ø10/40×3
15	301.801	Tapbout M8×16	Bolt M8×16
16	306.312	Zelfborgende moer M8	Self-locking nut M8
17	301.820	Tapbout M6×16	Bolt M6×16
18	306.707	Moer M6	Nut M6
19	301.809	Tapbout M10×20	Bolt M10×20
20	306.701	Moer M10	Nut M10
21	306.704	Moer M12	Nut M12
22	342.103	Smeernippel M10×1-180	Grease nipple M10×1-180
23	458.066	Pick-up tand	Pick-up tine
24	458.051	Tandveerbuis	Tine spring tube
25	301.747	Bout M8×50	Bolt M8×50
26	316.713	Sluitring R9	Washer R9
27	458.052	Klemstukje	Clamping piece
28	303.930	Verz.bout M12x40	Countersunk bolt M12x40
29	458.068	Moer M12	Nut M12

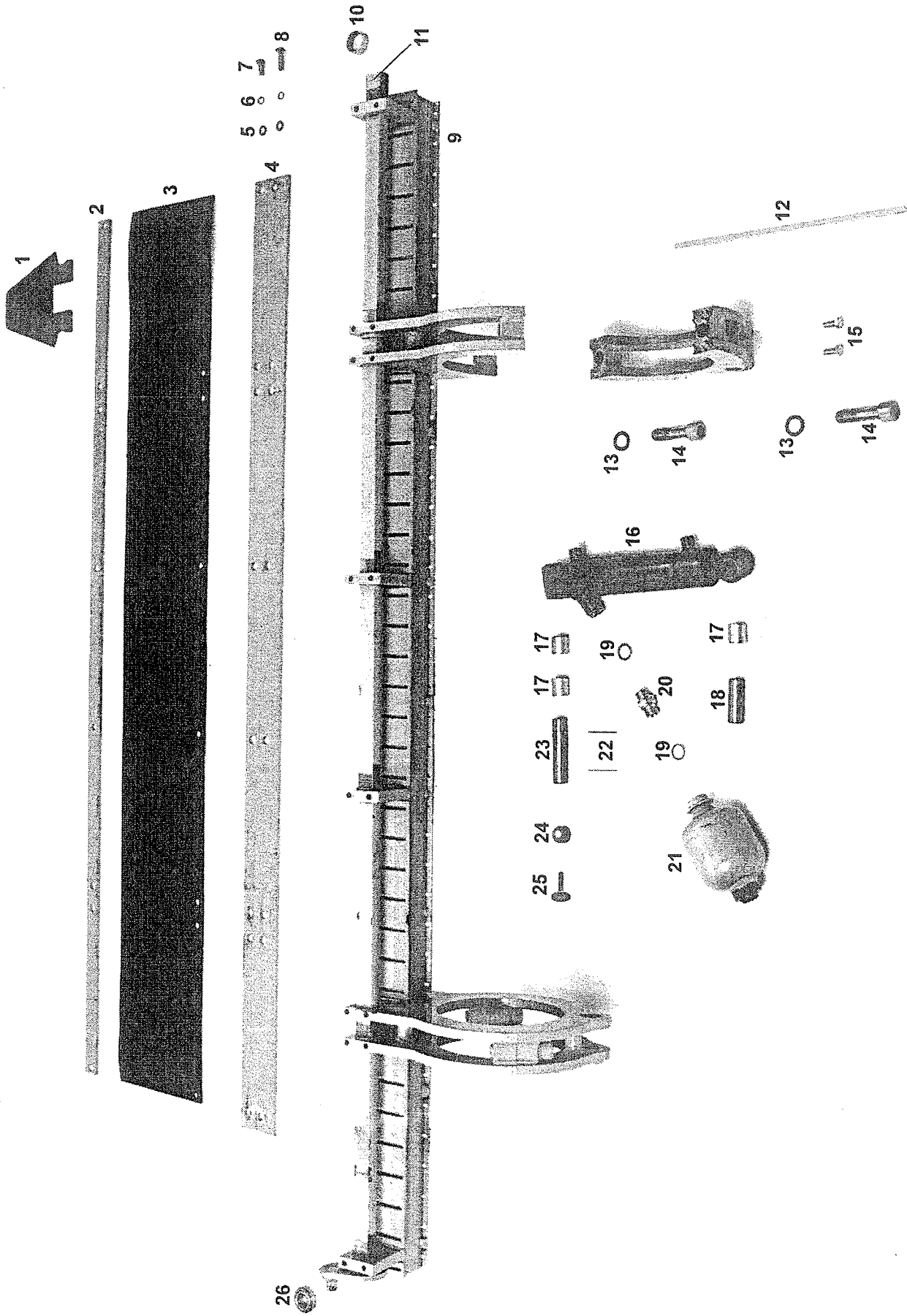

13. CHOPPING DEVICE

Snij-inrichting

<i>Fig.</i>	<i>SR-no.</i>	<i>Omschrijving</i>	<i>Description</i>
1	433.102	Mes	Knife
2	912.605	Klemstrip voor messenbalk	Clamping strip for cutter bar
3	374.175	Rubber afdichtstrook	Rubber sealing
4	912.604	Steunstrip	Support strip
5	316.705	Sluitring A10,5	washer A10,5
6	316.906	Veerring 10 mm	Spring washer 10 mm
7	301.809	Tapbout M10×20	Bolt M10×20
8	301.805	Tapbout M10×25	Bolt M10×25
9	960.248	Messenbalk (incl. 10 t/m 14)	Cutter bar (incl. 10 to 14)
10	402.130	Glijlager 30/15	Slide bearing 30/15
11	967.040	Messenborg-as	Knife-locking shaft
12	281.010	Kunststof glijstrook 8×4	Plastic sliding strip 8×4
13	316.919	Tandveerring J16,5	Toothed spring ring J16,5
14	302.622	Cilinder kopbout M16×60	Cylinder head bolt M16×60
15	301.801	Tapbout M8×16	Bolt M8×16
16	355.764	Hydr. cilinder D20-40/138 (incl. 17 en 17a)	Hydr.cylinder D20-40/138 (incl. 17 and 17a)
	454.811	Set afdichtingen t.b.v. N° 16	Set of seals for N° 16
17	402.129	Glijlager 20/25	Slide bearing 20/25
	402.128	Glijlager 20/20	Slide bearing 20/20
18	920.751	Scharnierpen	Pivoting pin
19	364.016	Dichtring	Sealing ring
20	900.105	Rechte fitting M18×1,5	Straight fitting M18x1.5
21	355.703	Hydraulische membraanaccu 80bar	Hydraulic membrane accumulator
22	312.113	Spanstift 6×36	Clamping pin 6×36
23	920.750	Scharnierpen	Pivoting pin
24	306.704	Moer M12	Nut M12
25	301.804	Bout M12x35	Bolt M12x35
26	401.201	Looprol LR 202 NPP	Runner roller LR 202 NPP

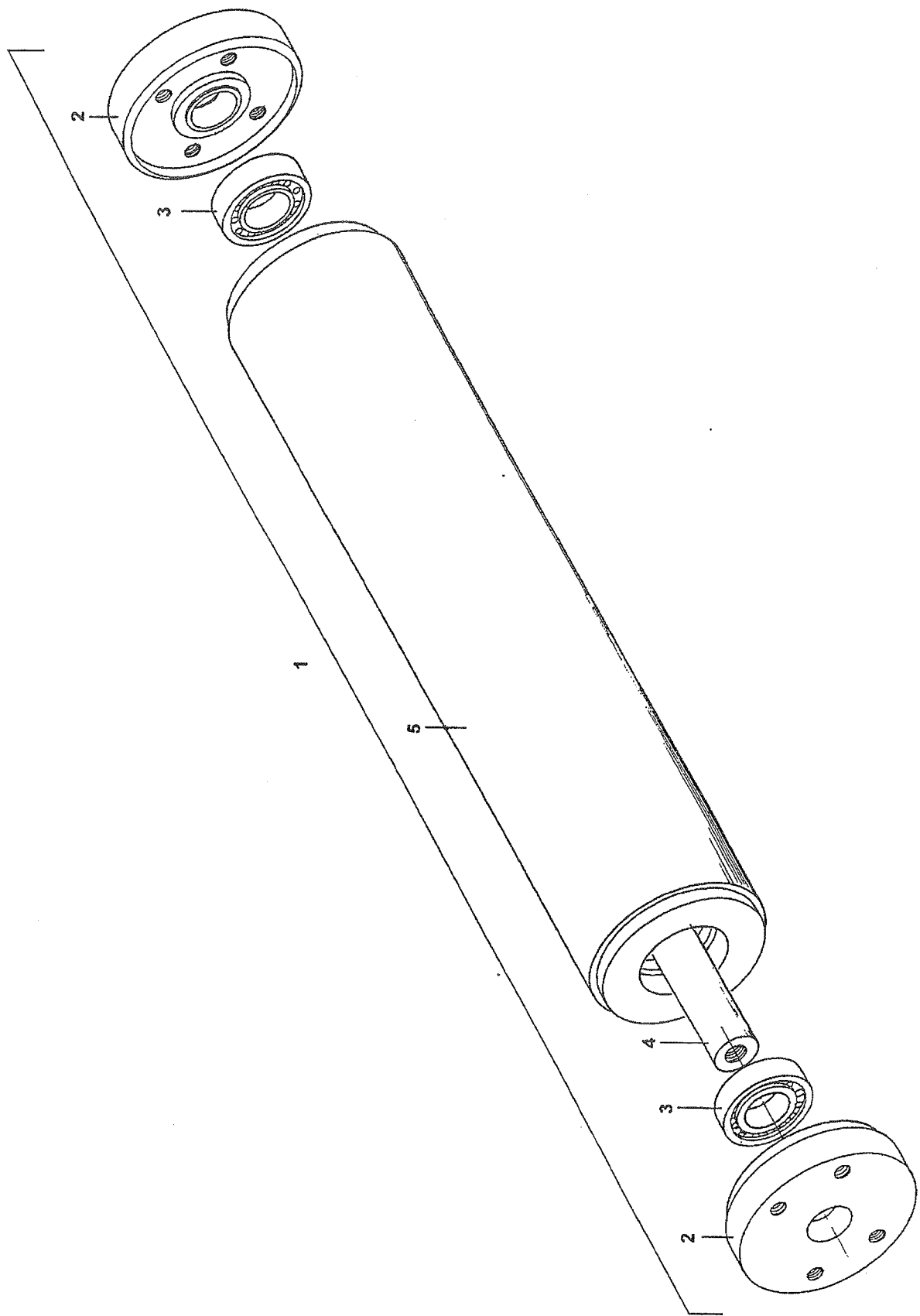

14. FEED ROLLER

INVOERROL

Drawing no. 975.010

<i>Fig.</i>	<i>SR-no.</i>	<i>Omschrijving</i>	<i>Discription</i>
1	953.503	Invoerrol complete Rap.100	Feed roller complete Rap.100
	953.574	Invoerrol compleet Rap. 130;160	Feed roller complete Rap.130;160
2	920.799	Eindflens	End flange
3	401.175	Kogellager 6207-2RS	Ball bearing 6207-2RS
4	920.801	Rol-as Rap.100	Roller shaft Rap.100
	921.055	Rol-as Rap.130 en 160	Roller shaft Rap.130 and 160
5	967.338	Invoerrol Rap. 100	Feed roller Rap.100
	968.734	Invoerrol Rap. 130 en 160	Feed roller Rap.130 and 160

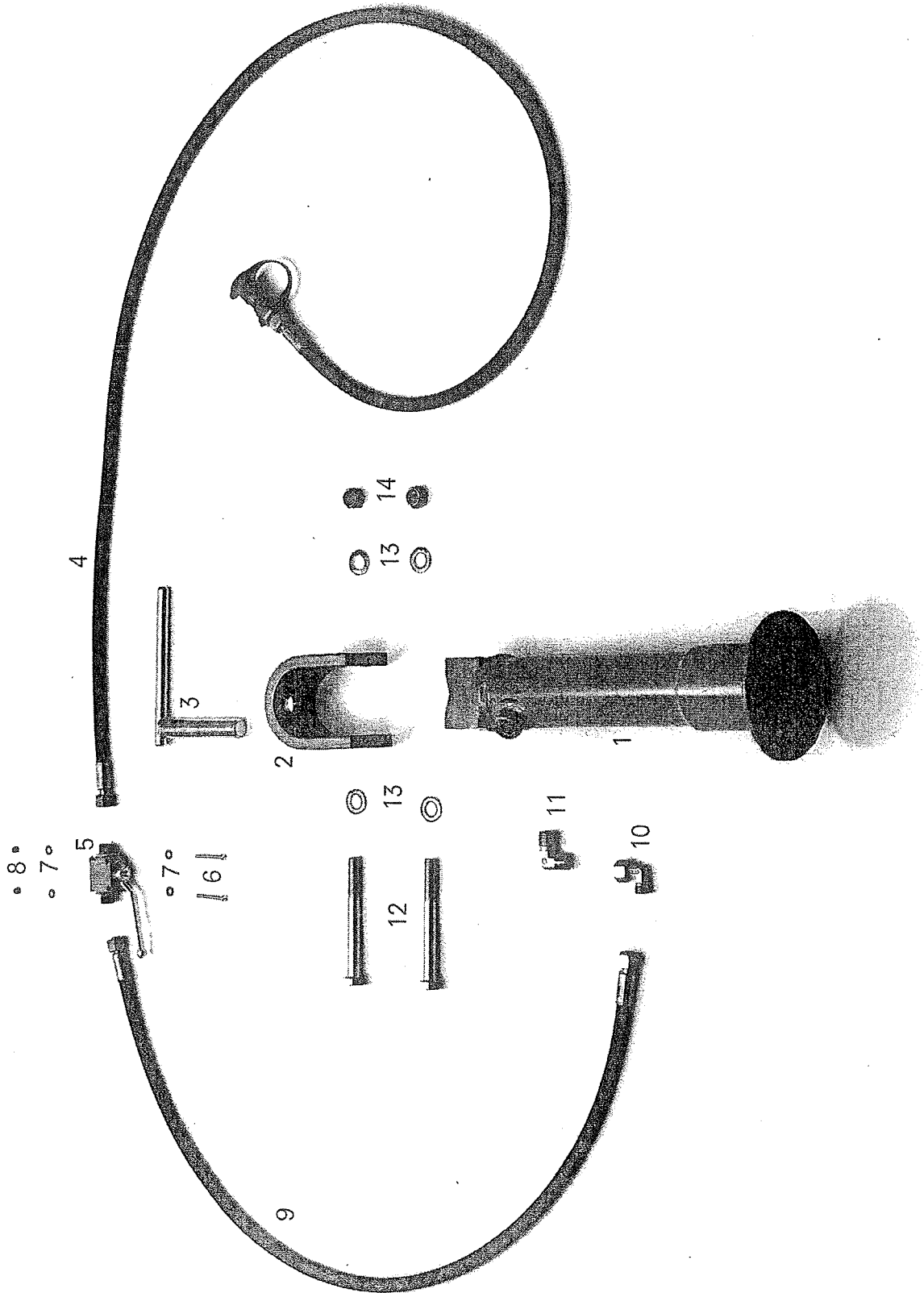

15. HYDRAULIC PARKING SUPPORT

HYDRAULISCHE STEUNPOOT

<i>Fig.</i>	<i>SR-no.</i>	<i>Omschrijving</i>	<i>Description</i>
1	967.781	Steunpootcilinder	Parking support cylinder
1a	454.059	Set afdichtingen t.b.v. N° 1	Set of seals for N° 1
2	911.784	Scharnierstuk	Hinge piece
3	967.780	Grendelpen	Locking pin
4	417.406	Hydr. slang	Hydr. hose
5	355.667	Tweeweg kogelkraan NW10	Two-way ball valve NW10
6	303.952	Cilinder kopschroef M5×45	Cylinder head screw M5×45
7	316.730	Sluitring A5,3	Washer A5,3
8	306.335	Zelfborgende moer M5	Self-locking nut M5
9	417.404	Hydr. slang	Hydr. hose
10	355.197	Instelbare haakse koppeling 12	Adjustable angle coupling 12
11	355.124	Haakse koppeling	Angle coupling
12	301.783	Bout M16×140	Bolt M16×140
13	316.707	Sluitring A17	Washer A17
14	306.303	Zelfborgende moer M16	Self-locking nut M16

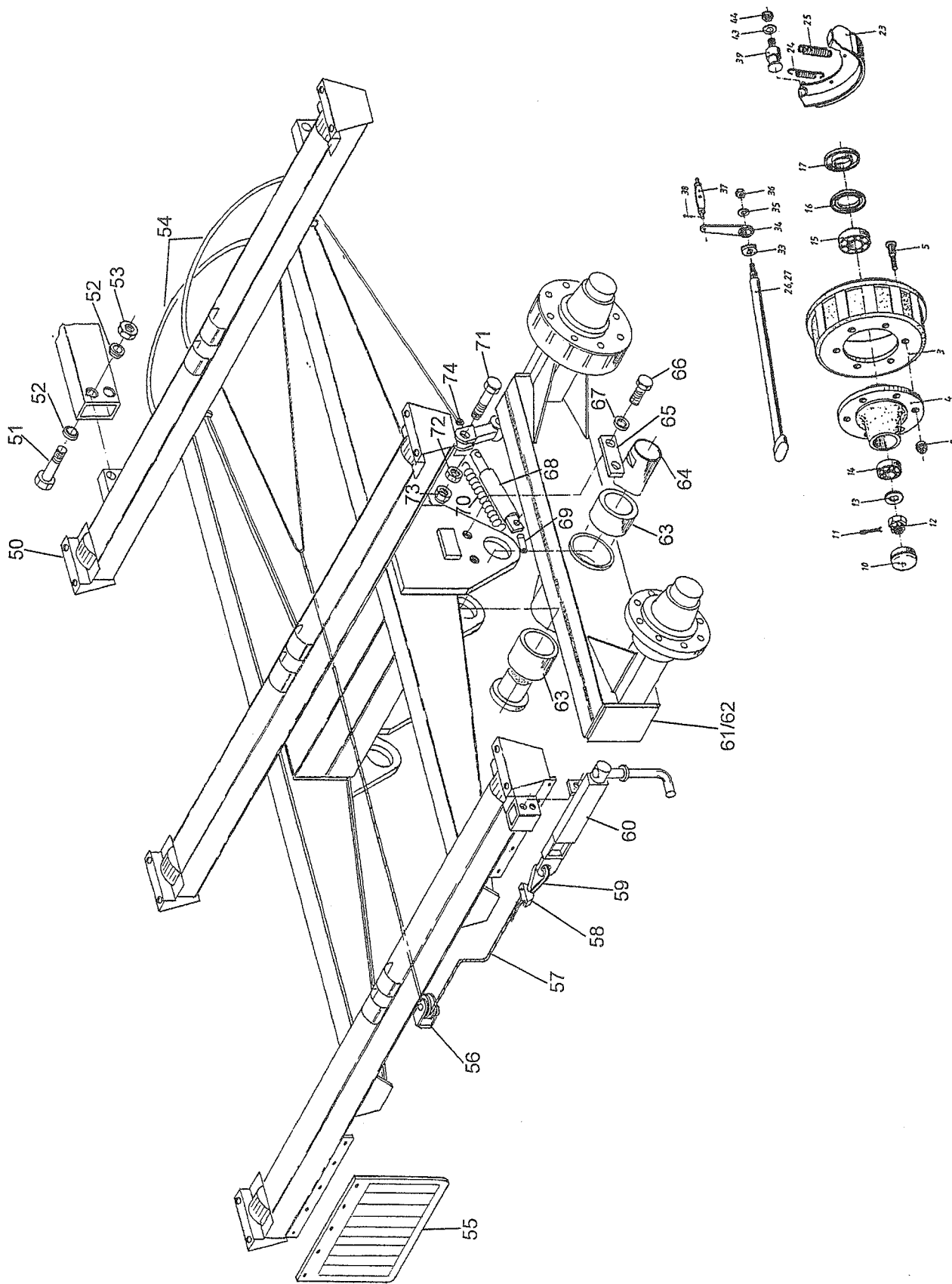

16. TANDEMFRAME TAP-BPW RAPIDE 130E

TANDEM FRAME TAP-BPW RAPIDE 130E

<i>Fig.</i>	<i>SR-no.</i>	<i>Omschrijving</i>	<i>Description</i>
3	452.042	Remtrommel 318-20	Brake drum 318-20
4	452.041	Wielnaaf 7008-20	Wheel hub 7008-20
5	450.835	Wielbout M20 x 54	Wheel bolt M20 x 54
	450.629	Wielbout M20 x 70	Wheel bolt M20 x 70
9	450.417	Wielmoer M20	Wheel nut M20
9a	450.631	Conische Veerring 20mm	Conical spring ring 20mm
10	450.634	Naafdop 90mm	Hub cap 90mm
11	375.124	Splitpen 6mm	Split pin 6mm
12	306.317	Kroonmoer M36 x 1,5	Castle nut M36 x 1.5
13	316.739	Schijf 37mm	Disc 37mm
14	450.319	Kegellager 30210	Cone bearing 30210
15	401.147	Kegellager 32014	Cone bearing 32014
16	452.011	Vetkeerring 32014	Oil catcher 32014
17	452.010	Steunring 32014	Supporting ring 32014
24	450.274	Trekveer	Draw spring
25	450.531	Trekveer	Draw spring
26	452.xxx	Remas	Brake shaft
33	450.535	Tandschijf	Toothed disc
34	450.534	Remhefboom	Brake lever
35	316.918	Veerring 24mm	Spring ring 24
36	306.717	Moer M24 x 1,5	Nut M24 x 1.5
39	452.021	Rembout 318	Brake bolt 318
43	316.918	Veerring 24mm	Spring washer 24mm
44	306.717	Moer M24 x 1,5	Nut M24 x 1.5
50	961.739	Tandemframe TAP-BPW	Tandem frame TAP-BPW
51	301.771	Bout M20 x 90	Bolt M20 x 90
52	316.311	Conische veerring 20mm	Conical spring ring 20mm
53	306.706	Moer M20	Nut M20
54	462.169	Buitenkabel	Cable protection
56	462.127	Kabelrol	Cable roller
57	378.132	Staalkabel 6mm	Steel cable
58	378.118	Kabelklem	Cable clamp
59	378.102	Puntkous	Cable lug
60	968.628	Parkeerrem	Parking brake
61	435.903	Pendelarm Li. 7008-318	Oscillating lever Left 7008-318
62	435.904	Pendelarm Re. 7008-318	Oscillating lever Right 7008-318
63	450.950	Glijlagerbus	Slide-bearing bush
64	435.907	Pendelas	Oscillating axle
65	435.908	Borgplaat	Locking plate
66	301.825	Bout M16 x 30	Bolt M16 x 30
67	316.901	Veerring 16mm	Spring washer 16mm
68	355.416	Remcilinder	Brake cylinder
68a	454.115	Set afdichtingen	Set of seals
69	312.113	Spanstift 6mm	Clamping pin
70	331.106	Trekveer	Draw spring
71	301.759	Bout M16 x 80	Bolt M16 x 80
72	306.702	Moer M16	Nut M16
73	306.303	Zelfborgende moer M16	Self-locking nut M16

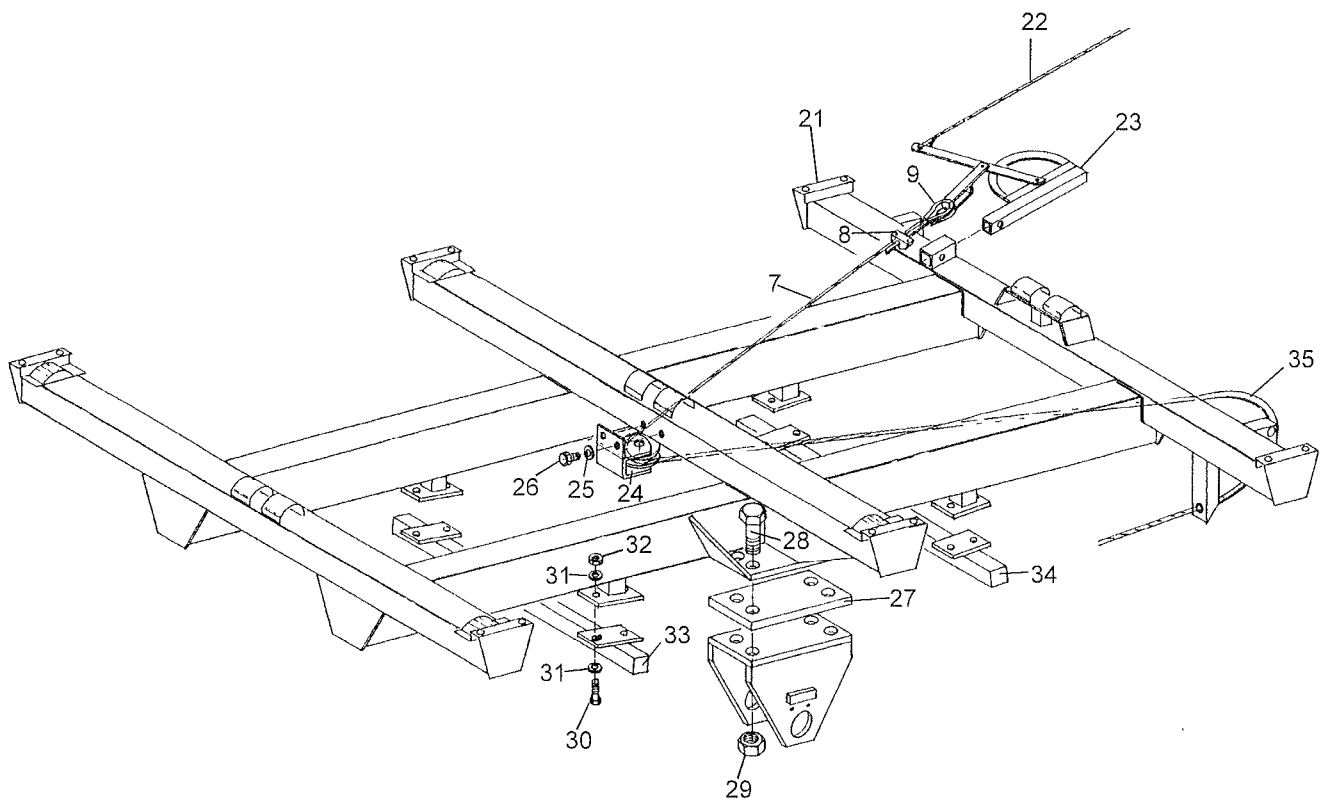
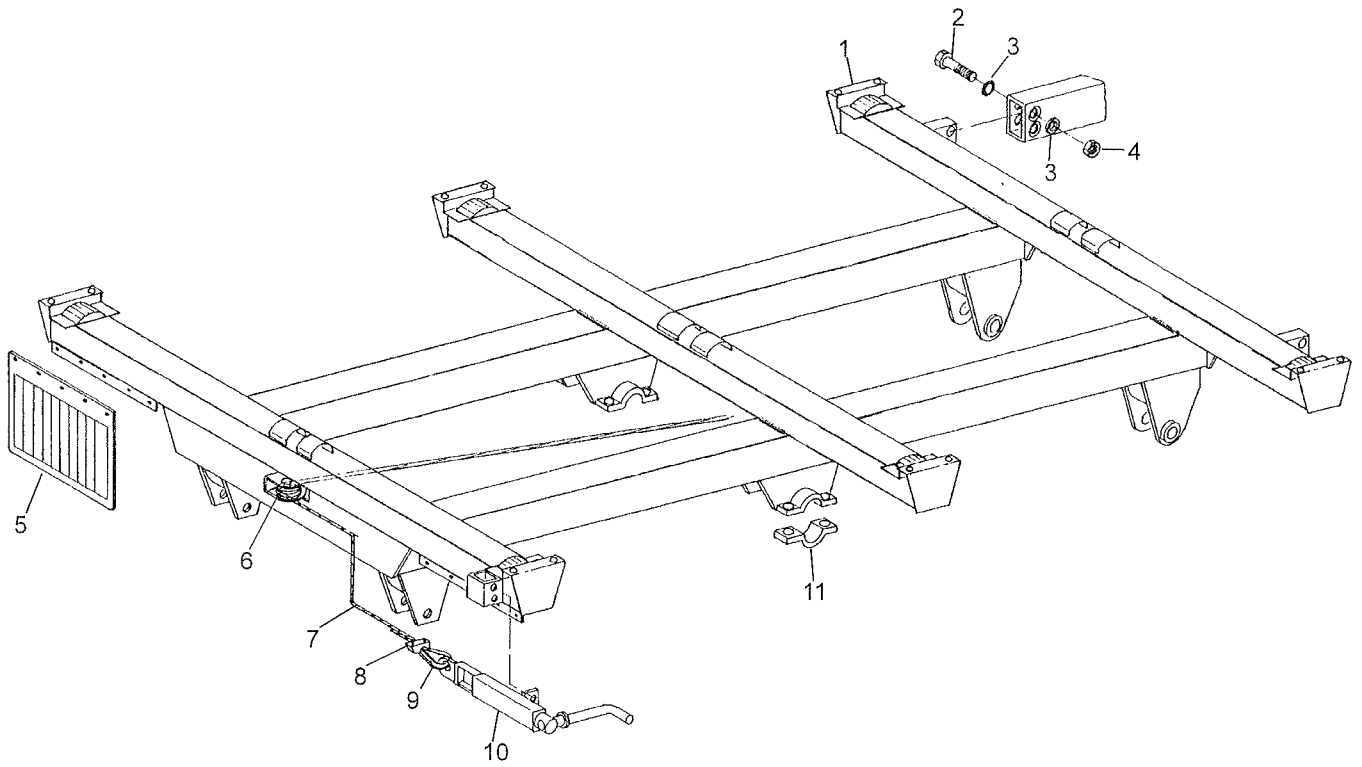

17. TANDEMFRAME SPRING ASSEMBLIE

TANDEM FRAME GEVEERD

<i>Fig.</i>	<i>SR-no.</i>	<i>Omschrijving</i>	<i>Description</i>
1	961.580	Tandemframe Rapide 130E	Tandem frame Rapide 130E
	960.517	Tandemframe Rapide 160 en 200	Tandem frame Rapide 160 and 200
2	301.771	Bout M20 x 90	Bolt M20 x 90
3	316.311	Conische veerring 20mm	Conical spring ring 20mm
4	306.706	Moer M20	Nut M20
5	374.167	Splatlap 500x400	Mud quard 500x400
6	462.127	Kabelrol	Cable roller
7	371.132	Staalkabel	Steel cable
8	378.118	Kabelklem	Cable clamp
9	378.102	Puntkous	Cable lug
10	968.628	Parkeerrem	Parking brake
11	462.555	Lagerschaal	Bearing cup

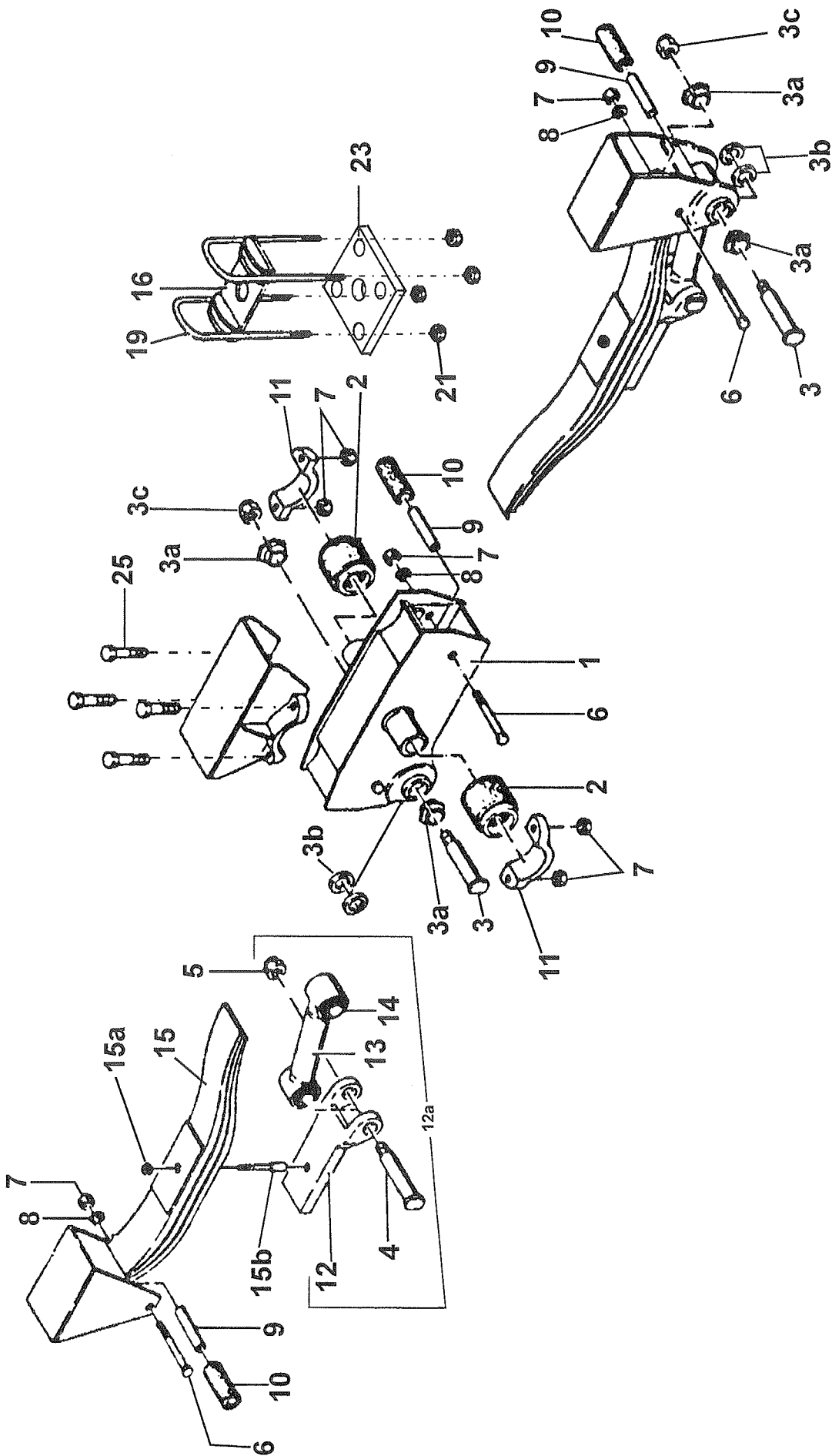

18. GIGANT SPRING ASSEMBLIES

GIGANT VEERSTELLEN

<i>Fig.</i>	<i>SR-no.</i>	<i>Omschrijving</i>	<i>Description</i>
1	462.513	Pendelstuk Rap.100 en 130	Oscillating piece Rap.100 and 130
	462.517	Pendelstuk Rap.160	Oscillating piece Rap.160
2	450.925	Rubberbus	Rubber bushing
3	462.538	Excenterbout (incl.3a, b en c)	Eccentric bolt (incl. 3a, b and c)
4	450.926	Veerbout M27×1,5 (incl. 5)	Suspension bolt (incl. 5)
5	450.927	Moer M27×1,5	Nut M27×1.5
6	301.716	Bout M16×130 Rap.100 en 130	Bolt M16×130 Rap.100 and 130
	301.713	Bout M16×160 Rap.160	Bolt M16×160 Rap.160
7	306.303	Zelfb. moer M16	Self-locking nut M16
8	316.707	Sluitring A17	Washer A17
9	926.273	Buisje L=96 Rap.130E	Bush L=96 Rap.130E
	926.274	Buisje L=116 Rap.160 en 200	Bush L=116 Rap.160 and 200
10	462.556	Rubberrol L=80 Rap.130E	Rubber roller L=80 Rap.130E
	462.557	Rubberrol L=100 Rap.160 en 200	Rubber roller L=100 Rap.160 and 200
11	462.555	Lagerschaal middenstoel	Bearing cup middle block
12	-	Veertrekplaat	Spring drawing plate
12a	462.531	Trekveearm 80/244 Rap.130E	Draw spring arm 80/244 Rap.130E
	462.534	Trekveearm 100/453 Rap.160 en 200	Draw springarm 100/453 Rap.160 and 200
13	-	Veertrekarm (incl. 14)	Spring draw arm (incl. 14)
14	450.944	Rubberbus	Rubber bushing
15	462.521	Veerpakket 80/1200 Rap.130E	Spring assembly 80/1200 Rap.1300E
	462.523	Veerpakket 100/1600 Rap.160 en 200	Spring assembly 100/1600 Rap.160 and 200
16	968.372	Veerplaat 80/100 Rap.130E	Spring plate 80/100 Rap.130E
	968.376	Veerplaat 100/110 Rap.160 en 200	Spring plate 100/110 Rap.160 and 200
19	462.542	Veerstrop M20×320 Rap.130E	Spring U-bolt M20×320 Rap.130E
	462.546	Veerstrop M24 x 360 Rap.160	Spring U-bolt M24 x 360 Rap.160
	462.548	Veerstrop M24×400 Rap.200	Spring U-bolt M24 ×400 Rap.200
21	462.551	Zelfb. moer M20×2,5 Rap.130E	Self-locking nut M20×2.5 Rap.13E
	462.552	Zelfb. moer M24×3 Rap.160 en 200	Self-locking nut M24×3 Rap.160 and 200
23	912.172	Veer-asplaat 80/100 Rap.130E	Spring axle plate 80/100 Rap.130E
	912.176	Veer-asplaat 100/110 Rap.160	Spring axle plate 100/110 Rap.160
	961.238	Veer-asplaat 100/110-40 Rap.200	Spring axle plate 100/110 with blockRap.200
25	301.745	Bout M16×70	Bolt M16×70

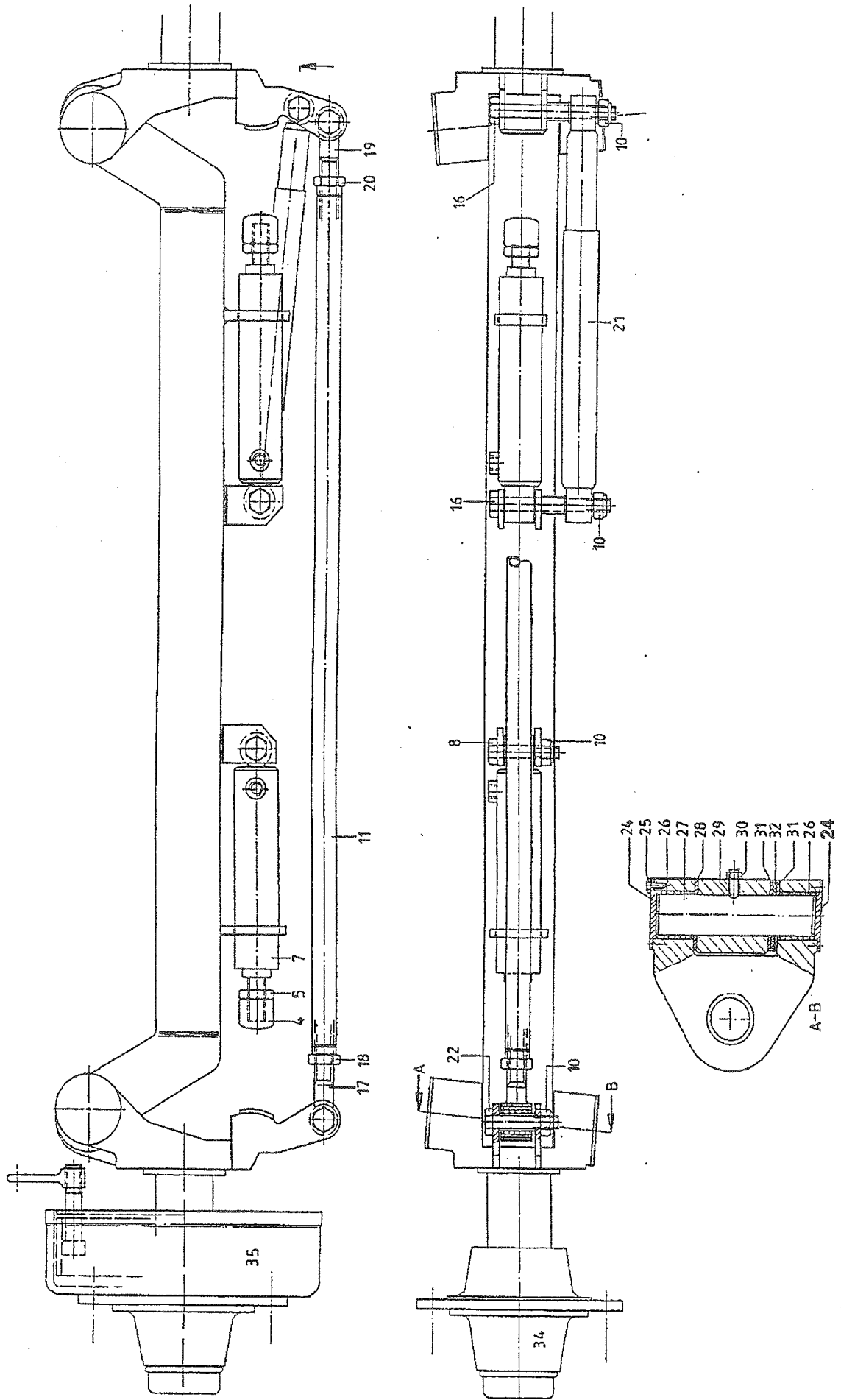

19. TRACK FOLLOWING WHEEL AXLE

MEELOPEND GESTUURDE WIELAS

Drawing no. 975.014

<i>Fig.</i>	<i>SR-no.</i>	<i>Omschrijving</i>	<i>Description</i>
1	435.804	Volg-as 10898 Rap.130E	Track-following axle 10898 Rap.130E
	432.070	Volg-as 1110 Rap.160 en 200	Track-following axle 1110 Rap.160 and 200
4	452.405	Dopmoer M27×3	Capped nut M27×3
5	306.368	Moer M27×3	Nut M27×3
7	452.404	Arreteercilinder	Stop-motion cylinder
8	301.781	Bout M20×130	Bolt M20×130
10	306.314	Zelfb. moer M20	Self-locking nut M20
16	301.795	Bout M20×190	Bolt M20×190
17	452.396	Draadeind M30×3,5L (incl. 17a)	Threaded end M30×3.5L (incl. 17a)
17a	452.398	Elastische lagerbus 20 / 38	Elastic bearing bush 20 / 38
18	306.361	Moer M30×3.5L	Nut M30×3.5
19	452.397	Draadeind M30×3,5R (incl. 17a)	Threaded end M30×3.5R (incl. 17a)
20	306.362	Moer M30×3,5R	Nut M30×3.5R
21	452.406	Schokdemper	Shock absorber
22	301.771	Bout M20×90	Bolt M20×90
24	452.395	Sluitdeksel	Cover
25	301.806	Bout M8×20	Bolt M8×20
26	452.391	Lagerbus	Bearing bush
27	452.390	Fusee-as	Swivel pin shaft
28	452.393	Axiaalschijf	Axial disc
29	304.115	Stelschroef M16×30	Setting screw M16×30
30	306.702	Moer M16	Nut M16
31	452.394	Vulschijf	Filler disc
32	452.393	Axiaalschijf	Axial disc
33	301.835	Bout M8×30	Bolt M8×30
34	-	Asstomp (zie blz. xx) Rap. 130	Shaft end (See page xx)Rap.130
	-	Asstomp (zie blz. xx) Rap. 160	Shaft end (See page xx)Rap.160

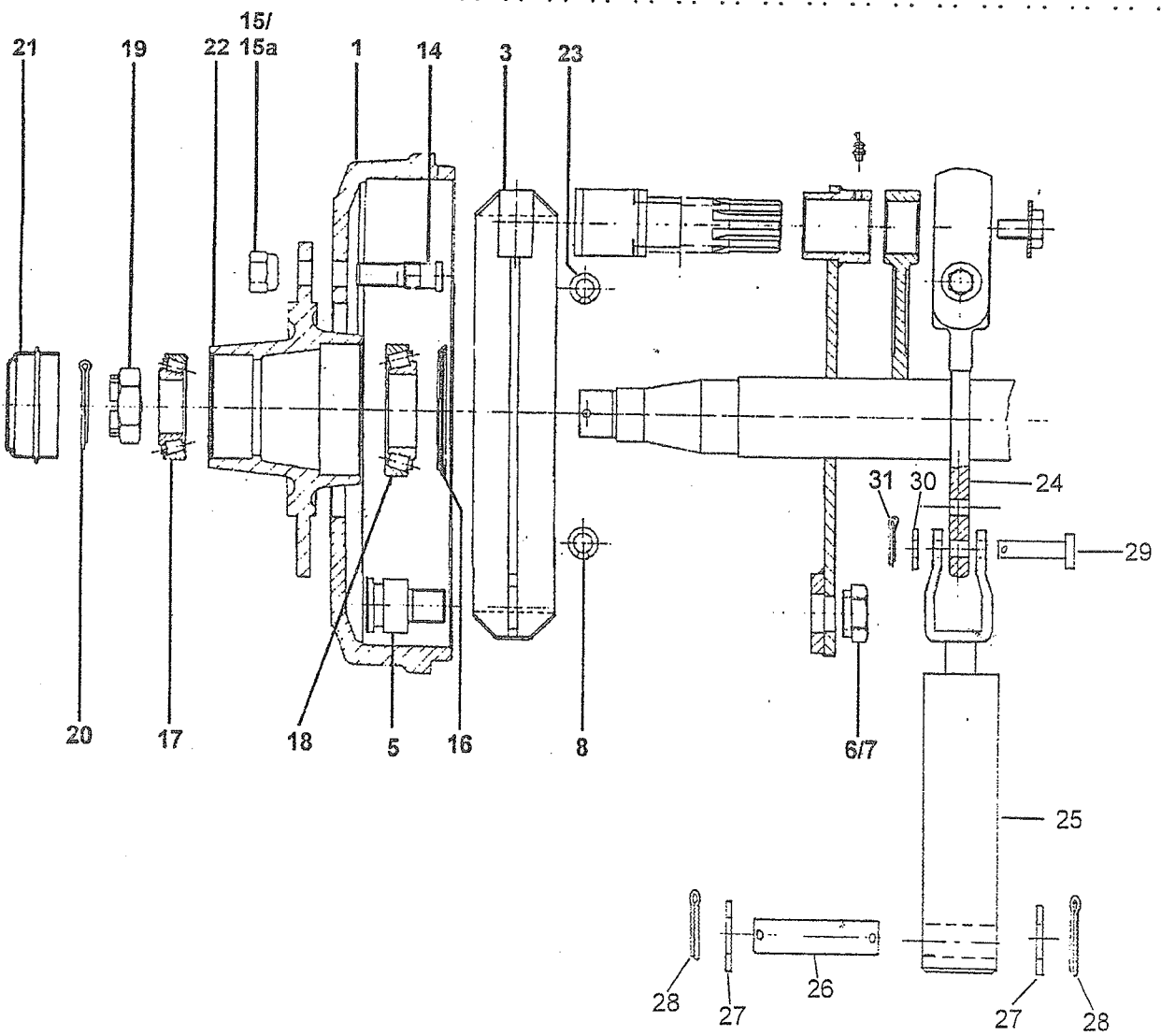
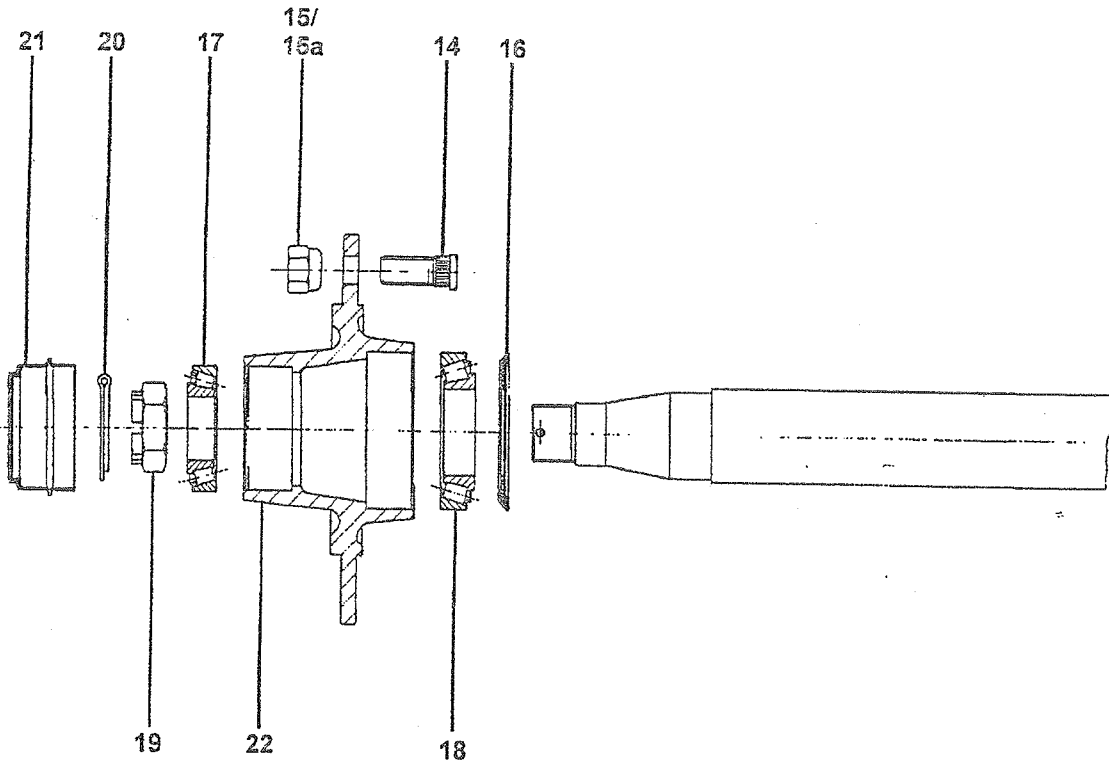

20. WHEEL AXLES ADR RAPIDE 130E (TYPE 898 BRAKE 300x90)

WIELASSEN ADR RAPIDE 130E (TYPE 898 REM 300x90)

<i>Fig.</i>	<i>SR-no.</i>	<i>Omschrijving</i>	<i>Description</i>
1	452.323	Remtrommel 300×90	Brake drum 300×90
3	452.337	Remschoen 300×90	Brake shoe 300×90
6	316.918	Veerring 24 mm	Spring ring 24 mm
7	306.717	Moer M24×1,5	Nut M24×1.5
8	452.345	Trekveer 300x90	Draw spring
14	450.629	Wielbout M20×1,5 L=70	Wheel bolt M20×1.5 L=70
15	450.630	Wielmoer M20×1,5	Wheel nut M20×1.5
15a	450.631	Bolle veerring 20 mm	Spring ring 20 mm
16	452.364	Dichtring	Sealing ring
17	401.145	Kegellager buiten 32212	Cone bearing outside 32212
18	401.196	Kegellager binnen 32215	Cone bearing inside 32215
19	452.358	Kroonmoer M48×1,5/75	Castle nut M48×1,5/75
20	375.142	Splitpen 4×80	Split pin 4×80
21	452.356	Naafdop Ø110 - schroefbevestiging	Hub cap Ø110 - screw fastening
22	452.311	Wielnaaf	Radnabe
23	452.343	Trekveer	Draw spring
24	452.385	Remhefboom 32	Brake lever 32
25	452.402	Remcilinder 25mm	Brake cylinder
26	920.673	Scharnierpen 20mm	Pivoting pin 20mm
27	316.725	Sluitring A21	Sealing ring A21
28	375.118	Splitpen 5x30	Split pin 5x30
29	349.076	Pen 14mm	Pin 14mm
30	316.741	Sluitring A15	Sealing ring A15
31	375.122	Splitpen 3x25	Split pin 3x25

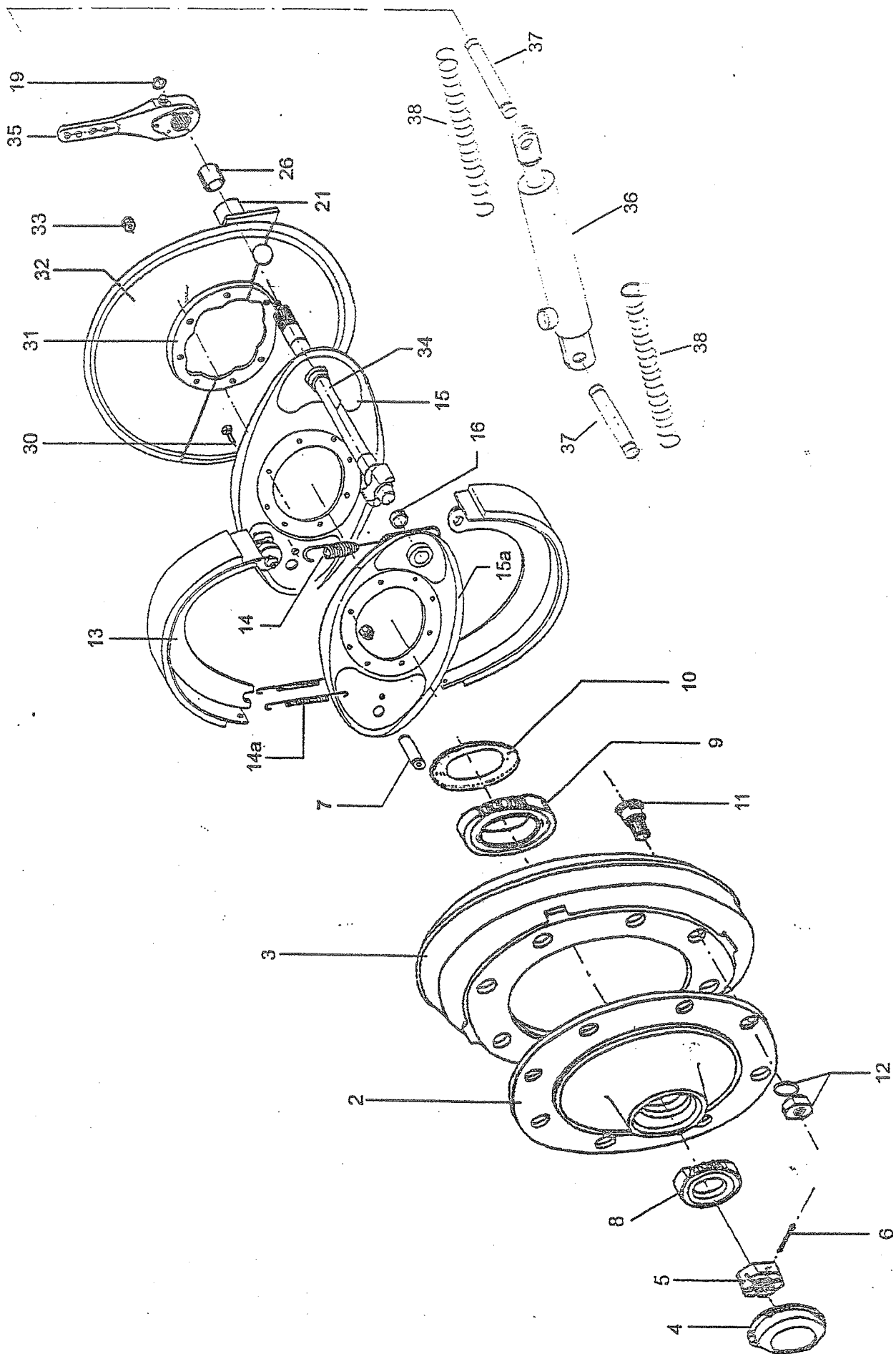

21. WHEEL AXLES COLAERT ((TYP 1110) BRAKE 406×120) RAPIDE 160 EN 200

WIELASSEN COLAERT ((TYP 1110) REM 406×120) RAPIDE 160 AND 200

<i>Fig.</i>	<i>SR-no.</i>	<i>Omschrijving</i>	<i>Description</i>
2	452.318	Wielnaaf	Radnabe
3	452.329	Remtrommel 406×120	Brake drum 406×120
4	452.350	Naafdop	Hub cap
5	452.386	Kroonmoer M70×1,5-90	Castle nut M70×1.5-90
6	375.139	Splitpen	Split pin
7	452.389	Remschoen as	Brake shoe shaft
8	401.196	Kegellager binnen 32215	Cone bearing inside 32215
9	401.273	Kegellager buiten 32218	Cone bearing outside 32218
10	452.382	Dichtring	Sealing ring
10a	452.383	Steunring voor dichtring	Supporting ring for sealing ring
11	452.335	Wielbout M22×1,5-96	Wheel bolt M22×1.5-96
12	450.735	Bolle veerring 22 mm	Spring ring 22 mm
12a	452.050	Wielmoer M22×1,5	Wheel nut M22×1.5
13	452.379	Remschoen 406×120	Brake shoe 406×120
14	452.349	Trekveer remstang zijde	Draw spring brake rod side
14a	452.348	Trekveer vaste zijde	Draw spring fixed side
15	452.454	Ankerplaat achterzijde	Anchor plate rear side
15a	452.455	Ankerplaat voorzijde	Anchor plate front side
16	452.457	Lagerbus S/Z nok	Bearing bush S/Z cam
19	313.106	Borgring A25	Locking ring A25
26	452.456	Lagerbus rem-as	Bearing bush brake shaft
30	452.429	Bout M12×35-10.9	Bolt M12×35-10.9
30a	452.430	Zelfb. moer M12	Locking nut M12
32	452.xxx	Dichtplaat	Sealing plate
33	306.306	Moer M10	Nut M10
34	452.464	Rem-as S-Nok	Brake shaft
	452.465	Rem-as Z-Nok	Brake shaft
35	452.387	Remhefboom Li.	Brake lever Left
	452.399	Remhefboom Re.	Brake lever Right
36	452.403	Remcilinder 30mm	Brake cylinder 30mm
37	452.408	Scharnierpen	Pivoting pin
38	331.103	Trekveer	Draw spring

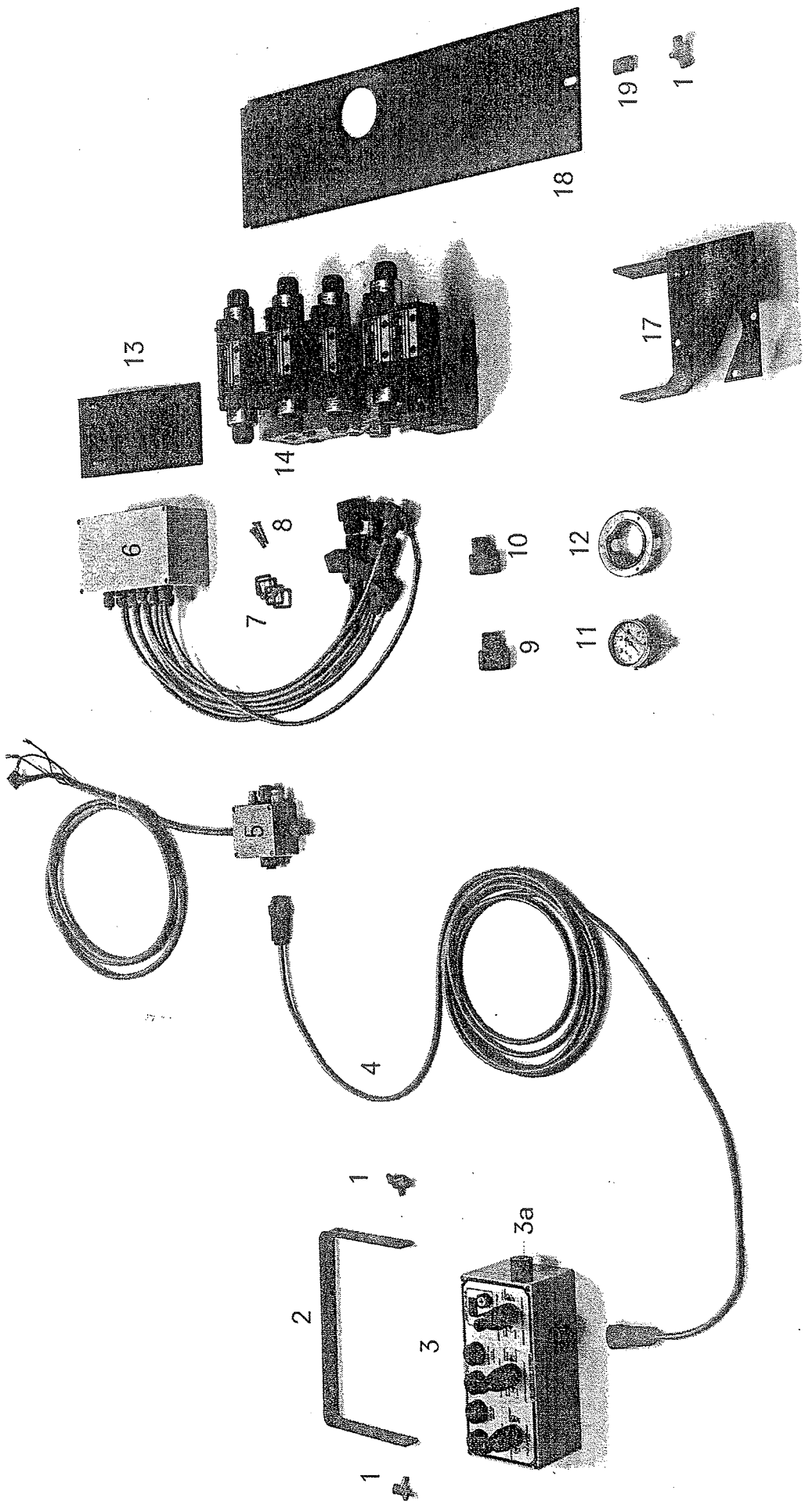

22. HYDRAULIC/ELEKTRICAL OPERATION

Hydraulisch/Elektrische bediening

<i>Fig.</i>	<i>SR-no.</i>	<i>Omschrijving</i>	<i>Description</i>
1	349.063	Vleugelknop M8×20	Wing nut M8×20
2	912.146	Bevestigingsbeugel	Mounting bracket
3	484.515	Bedieningsunit (incl. 3a t/m f)	Pilot box (incl. 3a up to f)
3a	349.067	Trillingsdemper	Vibration damper
3b	484.133	Kontaktblok	Contact block
3c	484.134	Schakelhandel-vast	Fixed switch lever
3d	484.135	Schakelhandel-verend	Spring switch lever
3e	484.132	Beschermhoes	Protective cover
3f	484.037	Signaallamp-rood	Warning light, red
3g	484.136	Drukschakelaar-rood	Pressure switch, red
3h	484.137	Drukschakelaar-groen	Pressure switch, green
3i	484.138	Impulsschakelaar "+"	Impulse switch "+"
3j	484.139	Impulsschakelaar "-"	Impulse switch "-"
3k	484.144	Chassisdeel met pen 4-polig	Surface-mounted connector 4P
4	484.602	Verbindingskabel	Connection cable
4a	484.142	Stekker met pen 4-polig	Straight cable connector 4P
	484.143	Stekker met bus 4-polig	Straight cable socket 4P
5	484.607	Voedingsunit	Supply unit
5a	484.144	Chassisdeel met pen 4-polig	Surface-mounted connector 4P
6	484.614	Stuurunit	Control unit
7	484.121	Dichtring GDM 3-16	Sealing ring GDM 3-16
8	484.122	Schroef M3×35	Screw M3×35
9	484.059	Connector zwart (incl. 7 en 8)	Connector, black (incl. 7, 8)
10	484.060	Connector grijs (incl. 7 en 8)	Connector, grey (incl. 7 and 8)
11	355.302	Manometer 0-250 bar	Manometer 0-250 Bar
12	355.303	Manometer-voorflens	Manometer front flange
13	961.109	Montage-steunplaat	Mounting-support plate
14	355.684	Hydraulisch manifold	Elektro-hydraulic manifold
17	961.108	Stuurblok-console	Manifold support
18	936.447	Sluitplaat	Locking plate
19	306.359	Plaatmoer M8 zelfborgend	Self-locking plate nut M8

23. FRONT BOARD RAPIDE 130E

VOORBORD RAPIDE 130E

Drawing no. 975.001

<i>Fig.</i>	<i>SR-no.</i>	<i>Omschrijving</i>	<i>Description</i>
1	301.739	Bout M10×90	Bolt M10×90
2	316.705	Sluitring A10,5	Washer A10,5
3	306.306	Zelfborgende moer M10	Self-locking nut M10
4	935.434	Deksel 25	Protective cover 25
5	376.141	Tulle	Tulle
6	301.836	Bout M16×45	Bolt M16×45
7	316.901	Veerring 16 mm	Spring washer 16 mm
9	371.294	Tuimelsluitng	Rocker fastening
11	301.809	Bout M10×20	Bolt M10×20
12	306.303	Zelfborgende moer M16	Self-locking nut M16
13	316.707	Sluitring A17	Washer A17
14	301.759	Bout M16×80	Bolt M16×80
15	301.771	Bout M20×90	Bolt M20×90
16	316.725	Sluitring A21	Washer A21
17	306.314	Zelfborgende moer M20	Self-locking nut M20
18	925.393	Busje L=37	Bush L=37
19	302.603	Cilinderkopbout M10×60	Cylinder head bolt M10×60
20	936.447	Sluitplaat	Locking plate
21	316.703	Sluitring A8,4	Washer A8,4
22	349.063	Vleugelknop M8×20	Wing nut M8×20
23	301.750	Bout M8×35	Bolt M8×35
24	333.001	Gasdrukveer	Gas pressure spring
25	967.607	Voorwand-zijstuk right	Front board side piece right
26	961.103	Voorwand-zijstuk links	Front board side piece left
27	967.602	Voorbord 2216	Front board 2016
31	967.142	Grendelpen	Locking pin
32	302.620	Cilinderkopbout M10×30	Cylinder head bolt M10×30
33	349.028	Kogel Ø10	Ball Ø10
34	331.202	Borgveer	Locking spring
35	900.115	Grendelbout M20×25	Locking bolt M20×25

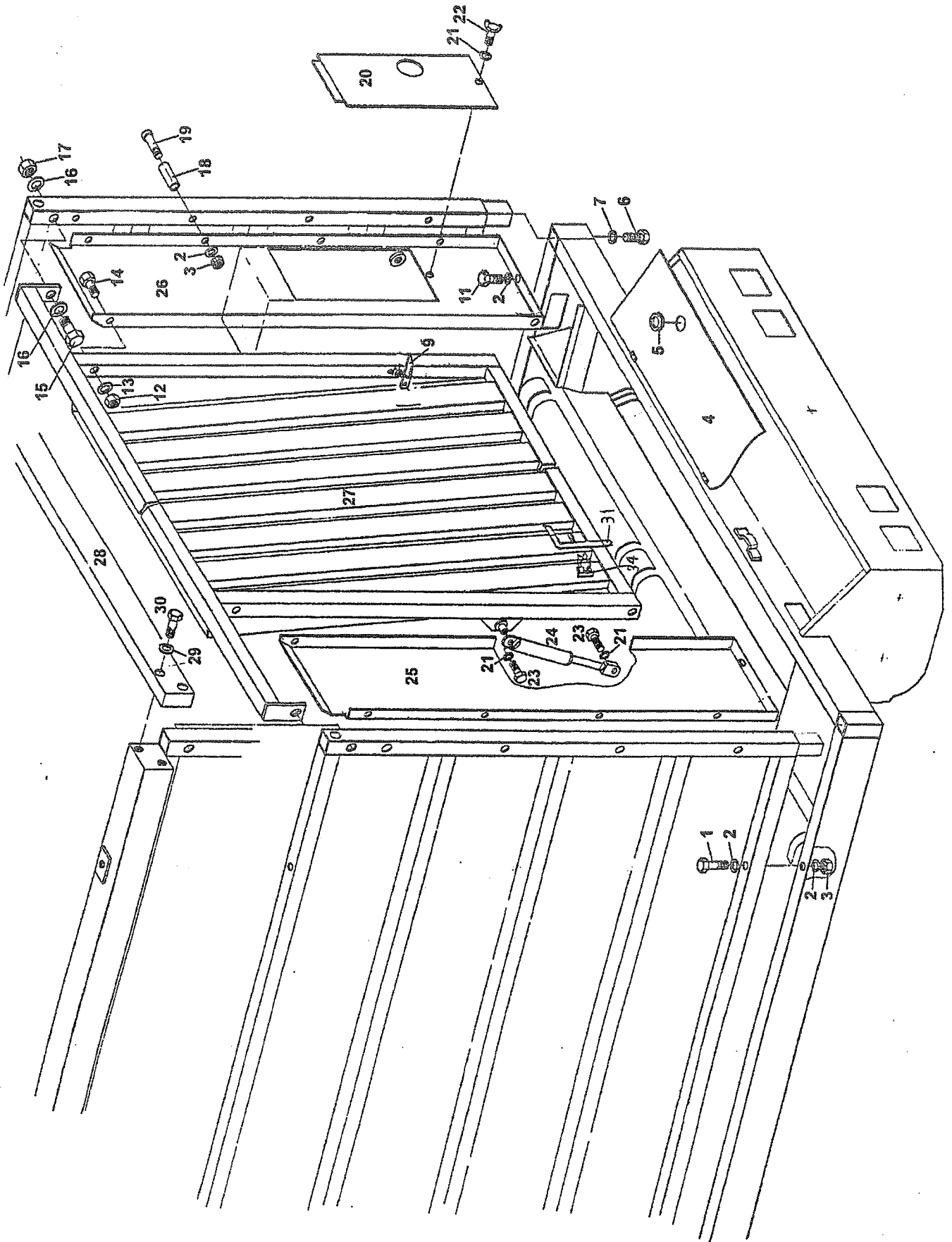

24. FRONT BOARD RAPIDE 160 AND 200

VOORBORD RAPIDE 160 EN 200

Drawing no. 975.001

<i>Fig.</i>	<i>SR-no.</i>	<i>Omschrijving</i>	<i>Description</i>
1	301.739	Bout M10×90	Bolt M10×90
2	316.705	Sluitring A10,5	Washer A10,5
3	306.306	Zelfborgende moer M10	Self-locking nut M10
4	935.434	Deksel 25	Protective cover 25
5	376.141	Tulle	Tulle
6	301.836	Bout M16×45 (achter)	Bolt M16×45 (rear)
	301.787	Bout M16×200 (voor)	Bolt M16×200 (front)
7	316.901	Veerring 16 mm	Spring washer 16 mm
9	371.294	Tuimelsluiting	Rocker fastening
11	301.809	Bout M10×20	Bolt M10×20
12	306.303	Zelfborgende moer M16	Self-locking nut M16
13	316.707	Sluitring A17	Washer A17
14	301.759	Bout M16×80	Bolt M16×80
15	301.771	Bout M20×90	Bolt M20×90
16	316.725	Sluitring A21	Washer A21
17	306.314	Zelfborgende moer M20	Self-locking nut M20
18	925.393	Busje L=37	Bush L=37
19	302.603	Cilinderkopbout M10×60	Cylinder head bolt M10×60
20	936.447	Sluitplaat	Locking plate
21	316.703	Sluitring A8,4	Washer A8,4
22	349.063	Vleugelknop M8×20	Wing nut M8×20
23	301.750	Bout M8×35	Bolt M8×35
24	333.001	Gasdrukveer	Gas pressure spring
25	961.107	Voorwand-zijstuk rechts	Front board- side piece right
26	961.106	Voorwand-zijstuk links	Front board- side piece left
27	961.273	Voorbord 2221	Front board 2221
28	968.419	Bovenrand 22	Top edge 22
29	316.702	Sluitring A13	Washer A13
30	301.785	Bout M12×80	Bolt M12×80
31	961.119	Grendelpen	Locking pin
34	330.002	Borgveer	Locking spring

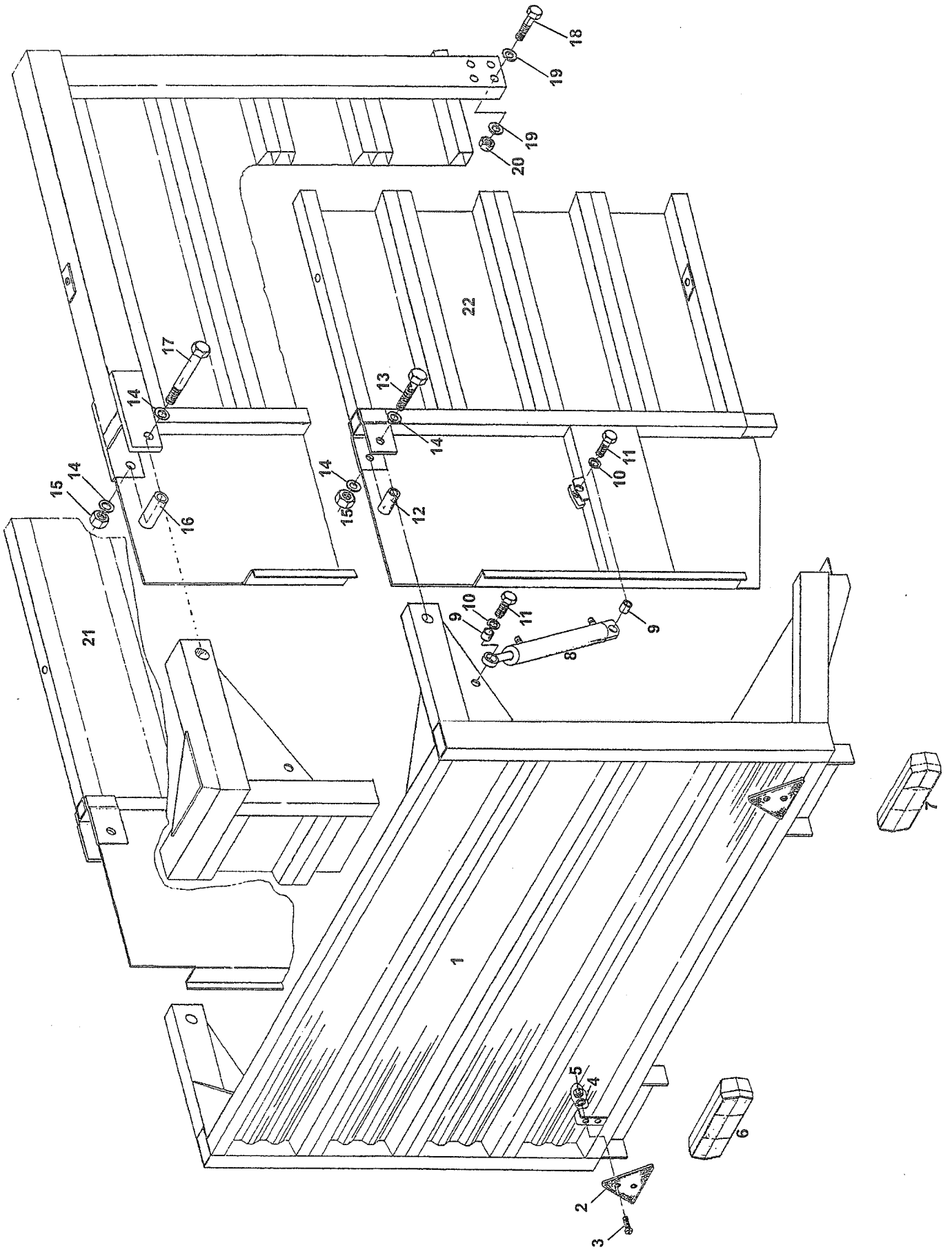

25. TAILGATE

ACHTERKLEP

Drawing no. 975.002

<i>Fig.</i>	<i>SR-no.</i>	<i>Omschrijving</i>	<i>Discription</i>
1	961.586	Achterklep Rap.130E	Tailgate Rap.130E
	968.431	Achterklep Rap.160 en 200	Tailgate Rap.160 and 200
2	482.201	Driehoek-reflector	Reflecting warning triangle
3	303.937	Cilinderkopschroef M5×12	Cylinder head screw M5×12
4	316.730	Sluitring A5,3	Washer A5,3
5	306.335	Zelfborgende moer M5	Self-locking nut M5
6	480.026	Achterlamp links	Rear light left
7	480.027	Achterlamp rechts	Rear light right
7a	482.104	Glas voor achterlicht	Glass for rear light
8	355.439	Hydr. cilinder Faroil Rap.130E	Hydr. Cylinder Faroil Rap.130E
	355.450	Hydr. cilinder Faroil Rap.160 en 200	Hydr. Cylinder Faroil Rap.160 and 200
8a	402.129	Glijlager 20/25	Slide bearing 20/25
8b	454.812	Set afdichtingen t.b.v. N° 8	Set of seals for N° 8
9	925.711	Lagerbusje	Bearing bush
10	316.707	Sluitring A17	Washer A17
11	301.737	Tapbout M16×50	Bolt M16×50
12	925.651	Scharnierbusje L=54 Rap.130E	Knuckle L=54 Rap.130E
13	301.762	Bout M16×90 Rap.130E	Bolt M16×90 Rap.130E
14	316.707	Sluitring A17	Washer A17
15	306.702	Moer M16	Nut M16
16	925.922	Scharnierbusje L=101 Rap.160 en 200	Knuckle L=101 Rap.160 and 200
17	301.738	Bout M16×150 Rap.160 en 200	Bolt M16×150 Rap.160 and 200
18	301.785	Bout M12×80	Bolt M12×80
19	316.701	Sluitring A13	Washer A13
20	306.302	Zelfborgende moer M12	Self-locking nut M12
21	961.582	Zijbord links Rap.130E	Side board left Rap.130E
	960.283	Zijbord links Rap.160	Side board left Rap.160
	961.210	Zijbord links Rap.200	Side board left Rap.200
22	961583	Zijbord rechts Rap.130E	Side board right Rap.130E
	960.284	Zijbord rechts Rap.160	Side board right Rap.160
	961.211	Zijbord rechts Rap.200	Side board right Rap.200

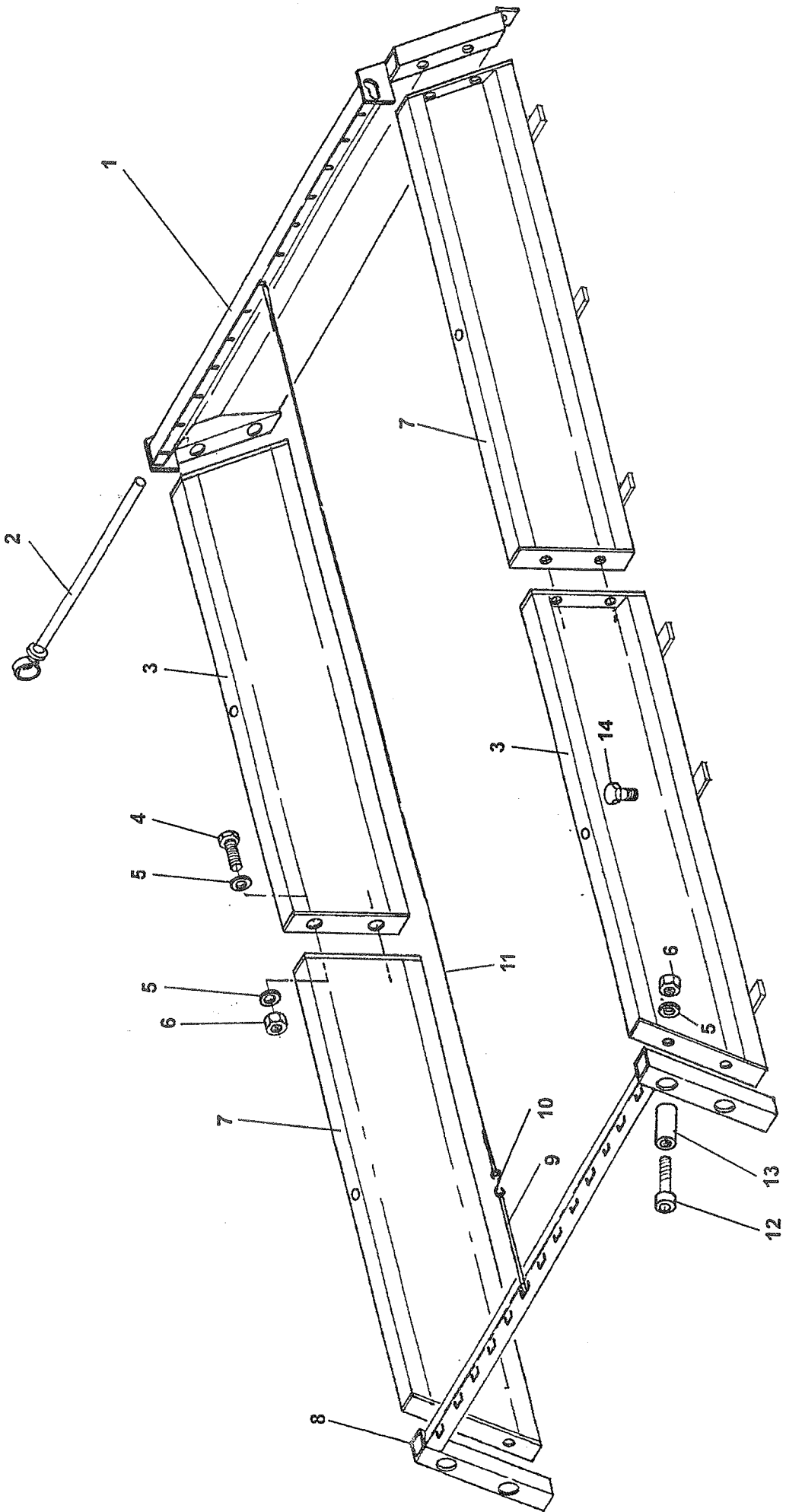

26. STEEL CONSTRUCTION + CORDS AS WINDCOVER

STALEN OPBOUW + KOORDEN ALS WINDKAP

Drawing no. 975.024

<i>Fig.</i>	<i>SR-no.</i>	<i>Omschrijving</i>	<i>Description</i>
0	994.442	Windkap Rap.130E	Wind cover, steel Rap.130E
	994.429	Windkap Rap.160	Wind cover, steel Rap.160
	994.430	Windkap Rap.200	Wind cover, steel Rap.200
1	961.588	Voorstuk met geleideplaat Rap.130E	Front part to lead Rap.130E
	961.271	Voorstuk met geleideplaat Rap.160 en 200	Front part to lead Rap.160 and 200
2	961.275	Kabelstang	Cable rod
3+7	967.572	Zijstuk Rap.130E	Side piece Rap.130E
3	961.575	Zijstuk-RH Rap.160	Side piece-RH Rap.160
	961.577	Zijstuk-RH Rap.200	Side piece-RH Rap.200
4	301.811	Bout M10x30	Bolt M10x30
5	316.705	Sluitring A10,5	Washer A10,5
6	306.306	Moer M10	Nut M10
7+3	967.572	Zijstuk Rap.130E	Side pice Rap.130E
7	961.574	Zijstuk-LH Rap.160	Side pice-LH Rap.160
	961.576	Zijstuk-LH Rap.200	Side pice-LH Rap.200
8	968.576	Achterbeugel Rap.130E	Rear bracket Rap.130E
	961.274	Achterbeugel Rap.160 en 200	Rear bracket Rap.160 and 200
9	900.300	Spankoord-40	Dragband-40
10	461.150	D-sluiting	D-locking clamp
11	900.301	Koord 8/4320 Rap.130E	Cord 8/4320 Rap.130E
	900.284	Koord 8/5720 Rap.160	Cord 8/5720 Rap.160
	900.285	Koord 8/6920 Rap.200	Cord 8/6920 Rap.200
12	302.603	Cilinderkopbout M10x10	Cylinder head bolt M10x60
13	925.393	Buisje L=37	Bush L=37
14	301.769	Bout M10x130 Rap.130E	Bolt M10x130 Rap.130E
	301.811	Bout M10x30 Rap.160 en 200	Bolt M10x30 Rap.160 and 200

27. HYDRAULIC SYSTEM RAPIDE 130E

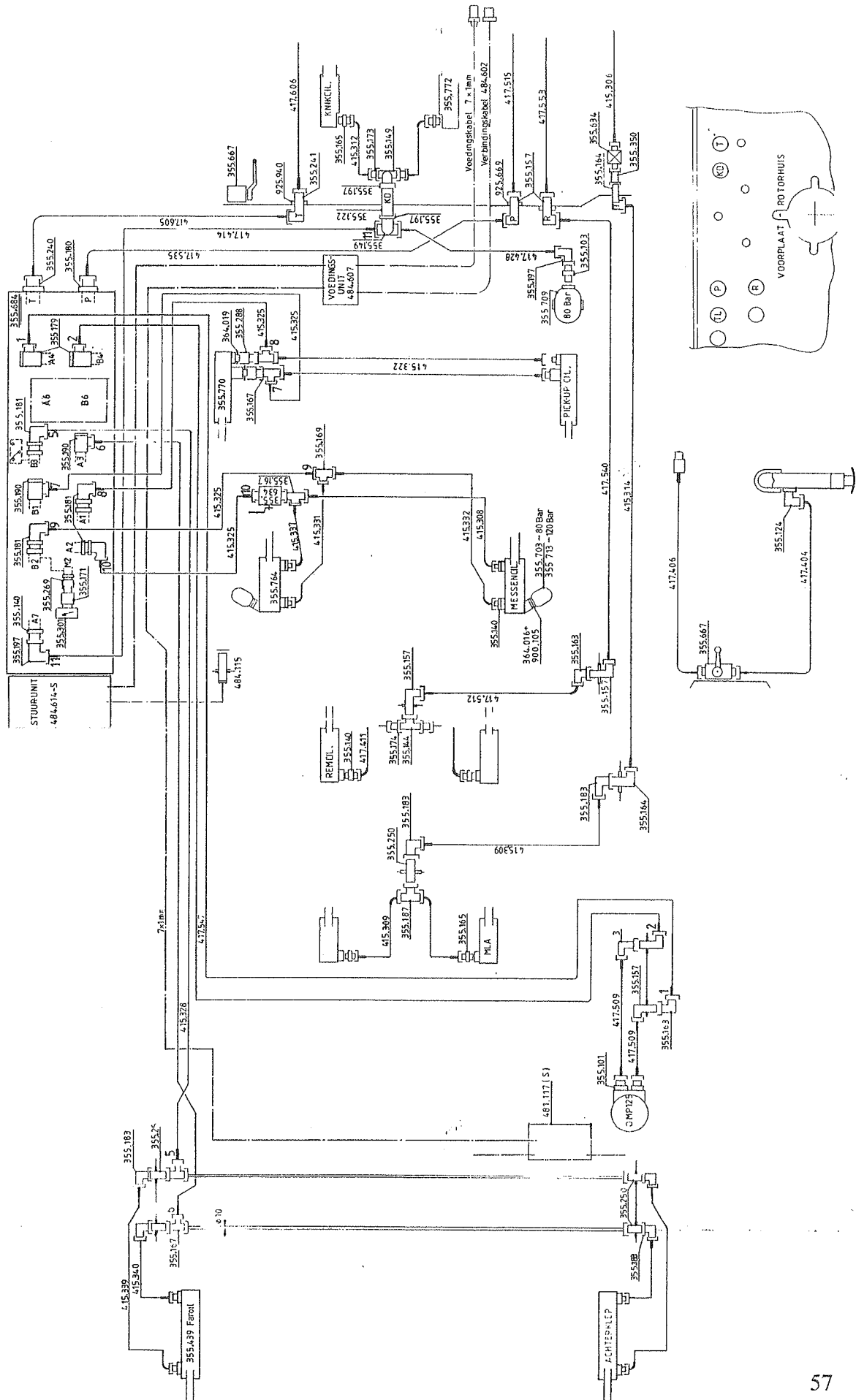

28. HYDRAULIC SYSTEM RAPIDE 160 AND 200

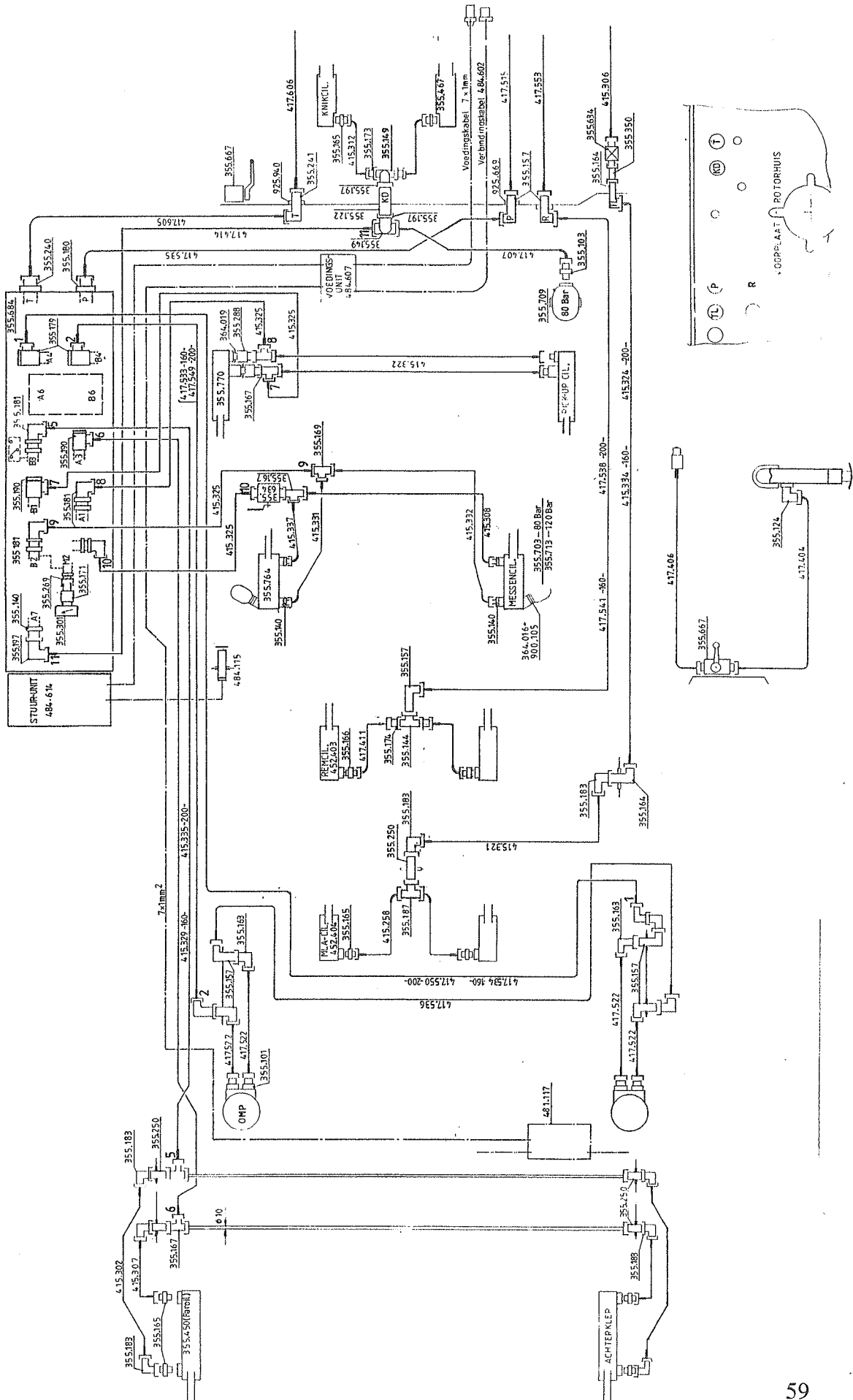

29. ELECTRICAL CIRCUIT DIAGRAM RAPIDE S

